

NOZZLE SCHEDULE							
ITEM	SIZE	RATING	TYPE	MATL	PROJ IN	PROJ OUT	REMARKS
A	4"	N.P.T.	W.F.	C.S.	STD.	STD.	EMERGENCY VENT OPENING
B	2"	N.P.T.	W.F.	C.S.	STD.	STD.	

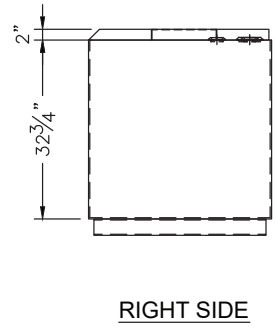
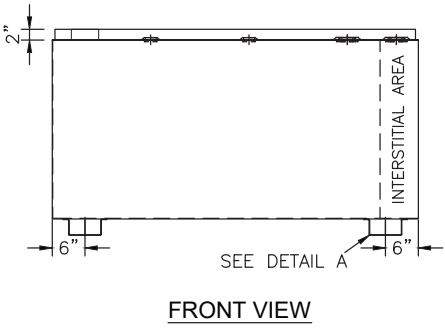
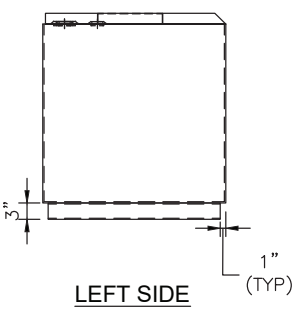
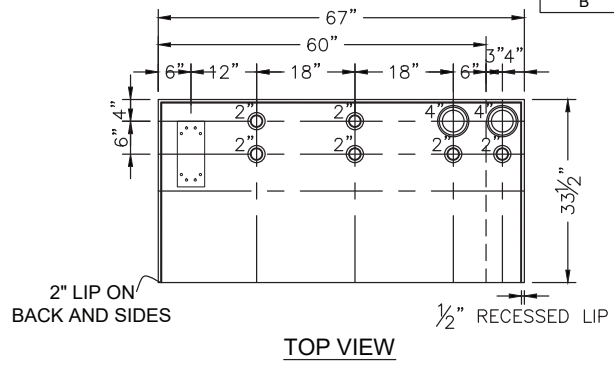
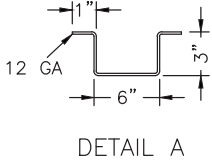

NOTES:

- A. Quantity:
- B. Material: H.R. Carbon Steel
- C. Tank: 12 GA w/ 10 GA Common Top
- D. Design & Operating Pressure: Atmospheric.
- E. Design & Operating Temperature: Ambient.
- F. Tank to be Built & Labeled per U.L. Spec. #142.
- G. Tank to Bear Manufacturers & U.L. Labels Only.
- H. Tank to be Air Tested with Water & Soap Suds Solution.
- I. Interior: Remove Weld Slag (Ship Clean & Dry).
- J. Exterior: Painted in Blue Acrylic Enamel Paint.
- K. All Fittings to be Protected for Shipment.
- L. Customer has the Responsibility to Verify All Dimensions.

*All pages of this Schedule A are incorporated by reference and are a part of the additional terms of the Master Terms & Conditions of Sale.
www.newberrytanks.com/masterterms.pdf

APPROVAL FOR CONSTRUCTION
 SCHEDULE A - MASTER TERMS & CONDITIONS OF SALE*

APPROVED AS DRAWN.

APPROVED WITH NOTED CHANGES. CONSTRUCTION WILL BE SCHEDULED WHEN SIGNED DRAWING AND CONFIRMED ORDER ARE RECEIVED.

SIGNATURE _____

DATE: _____

SALES ORDER #

FLUIDALL® 860 Johnson Drive
 Delano, MN 55328
www.fluidall.com

VESSEL DESCRIPTION:
 280 GALLON RECTANGULAR UL 142 DOUBLE WALL BENCH TOP TANK

CUSTOMER: _____ P.O.# _____

DATE: _____ SCALE: _____ DWG.# SDWBTT280 DRAWN BY: TC
 CHKD. BY: TB