



2026 VOLUME 26.A Parts Directory



World Class Fluid Storage & Handling Solutions

www.fluidall.com | 800.849.0591













PROUDLY CRAFTED IN THE USA

Stackable Poly Tanks

Purchase Fluids in Bulk: Reduce Total Fluid Expenses and Eliminate Waste from Packaged Goods & 55 Gallon Drums.

Stackable Tank Construction

- Constructed from UL Rated Food-Grade Polyethylene Resins
- Convenient and Easy Fill Tank Designs
- Translucent Tank with Fluid Level Markers
- 2" Fill Port(s) Located on the Top of Each Tank
- Bottom Stainless Steel Dispense Fittings
- Secure Tank Stacking with Interlocking Top and Bottom Points
- Extra Strength Corrugated Side Walls

	Small Tote-A-Lube Tanks	Large Tote-A-Lube Tanks	Wall-Stacker Tanks	Slimtainer Tanks	Cubetainer Tanks
					
					
Tank Footprint	32" x 32"	42" x 42"	Narrow 38" x 19"	Narrow 22" x 54"	36" x 36"
Tank Capacities	35, 70, 120 Gallons	130, 180, 240, 330 Gallons	32, 71, 115 Gallons	120 Gallons	60, 80, 120, 180, 260 Gallons
Tank Material	Tanks are Constructed with UL Rated Food-Grade Polyethylene Resin				
Top Fill Port	(1) Angled Fill Port w/ 2" NPT Poly Cap	(1) Angled Fill Port w/ 2" NPT Poly Cap	(2) Angled Fill Ports w/ 2" NPT Poly Cap	(1) 2" Center Fill Opening	(1) 2" Center Fill Opening
Top Tank Openings	2" NPT Plug	2" NPT Plug	N/A	(2) 2" NPT	(1) 2" NPT
Bottom Dispense Fitting	(1) 1" NPT Stainless Steel	(1) 1" NPT Stainless Steel	(1) 1" NPT Stainless Steel	(3) 1" NPT Stainless Steel	(2) 1" NPT Stainless Steel
Front Molded Inserts	120 Gallon Tank Only	Yes	N/A	N/A	120, 180, 260 Gallon Tanks
Side Molded Inserts	N/A	Yes	N/A	N/A	80, 120, 180, 260 Gallon Tanks
Top Molded Inserts	120 Gallon Tank Only	Yes	N/A	N/A	N/A
Side Walls	Corrugated Tank Wall Design Adds Extra Strength				
Fluid Level Markings	Molded In (Gallons)	Molded In (Gallons)	Molded In (Gallons)	Molded In & Inked (Gallons & Liters)	Molded In & Inked (Gallons & Liters)

Stackable Tank Storage & Handling Solutions

Our Space-Saving Multi-Fluid Storage and Handling Solutions are Backed by Decades of Reputable Industry Experience

Maximize Valuable Floor Space

Space saving stackable fluid storage and handling systems can open up valuable floor space to allow for additional revenue-producing shop work space or the expansion of the number of service bays.

Eliminate the Hassles of 55 Gallon Drums

- Messy clutter
- Down-time moving drums
- Unused product
- Potential Contamination

Flexibility to Move Fluids Throughout Your Shop





Convert a stationary system into portable storage with caster wheels to point-of-use dispense. Simply roll the system to the service area, attach air or electrical connections, and you can service multiple bays.

Ensure EPA Compliance With The Latest SPCC Plan Regulations

Our secondary containment vessels provide an excellent secondary barrier between the tank and the environment. Primary tanks combined with secondary containment provide a clean, space saving solution to meet SPCC guidelines and 40 CFR 264.175 requiring 110% capacity of the largest primary tank within a stack or 110% capacity of a single primary tank within the containment.

A Refillable Bulk Storage System Is a One-Time Investment That Stores and Handles Oils and Automotive Style Fluids



	Small Tote-A-Lube Gravity Feed Systems	Large Tote-A-Lube Gravity Feed Systems	Wall-Stacker Gravity Feed Systems	Slimtainer Gravity Feed Systems	Cubetainer Gravity Feed Systems
					
System Footprint	36"W x 44"D	43"W x 54"D	38"W x 30"D	64.5"W x 23"D	36"W x 48"
Tank Capacities	35, 70, 120 Gallons	130, 180, 240, 330 Gallons	32, 71, 115 Gallons	120 Gallons	60, 80, 120, 180, 260 Gallons
Gravity Feed Systems	Each Gravity Feed System includes the stackable tanks, stand with 24" legs, drip tray assembly, stainless steel dispense valves and the gravity feed kit to complete all connections.				
Secure Tank Stacking	Interlocking Top & Bottom Ridges. Tanks are Stackable within Exact Footprint Dimensions.				
Wall Straps	Required on Select Configurations		Required	N/A	N/A
Leg Brace	Required on Select Configurations		N/A	N/A	N/A

Small Tote-A-Lube Tanks 35, 70 and 120 Gallons

T120

(4) 3/8-16 Molded Inserts on Top Surface (Secures Top Mount Dispense Accessories)

T120

(2) 1/4 Molded Inserts on Front Surface (Secures Placard)



Angled Fill Port with 2" NPT Poly Cap

2" NPT Plug

1" NPT Stainless Steel Dispense Fitting

Small Tote-A-Lube Tanks			
Part No.	T35	T70	T120
Tank Capacity	35 Gallons	70 Gallons	120 Gallons
Tank Dimensions	32"W x 32"D		
Tank Height	13"H	23"H	35"H
Tank Weight	23 Lbs.	32 Lbs.	50 Lbs.

Large Tote-A-Lube Tanks 130, 180, 240 and 330 Gallons

2" NPT Plug

Angled Fill Port with 2" NPT Poly Cap



(4) 3/8-16 Molded Inserts on Top Surface (Secures Top Mount Dispense Accessories)

(6) 3/8-16 Molded Inserts on Side Surface (Secures Side Mount Dispense Accessories)

T130 / T180

(2) 1/4-20 Molded Inserts on Front Surface (Secures Placard)

T240 / T330

(2) 3/8-16 Molded Inserts on Front Surface
(2) 3/8-16 Molded Inserts on Back Surface (Secures Placard & Hoop)

1" NPT Stainless Steel Dispense Fitting



Large Tote-A-Lube Tanks				
Part No.	T130	T180	T240	T330
Tank Capacity	130 Gallons	180 Gallons	240 Gallons	330 Gallons
Tank Dimensions	42"W x 42"D			
Tank Height	26"H	35"H	45"H	59"H
Tank Weight	58 Lbs.	76 Lbs.	135 Lbs.	165 Lbs.

Gravity Feed Systems





T120-3 Gravity Feed System Shown with Recommended Top Tank Remote Fill Kit and Containment Vessel. See Accessories Pages 6-7.

Small Tote-A-Lube Gravity Feed Systems 35, 70 and 120 Gallon Tanks

Small Tote-A-Lube Gravity Feed Systems											
Includes: Tank(s), 24"H Stand, Drip Tray Assembly and Gravity Feed Dispense Kit. 36"W x 44"D Assembled.	35 Gallon				70 Gallon				120 Gallon		
											
Part No.	T35-1	T35-2	T35-3	T35-4	T70-1	T70-2	T70-3	T70-4	T120-1	T120-2	T120-3
No. of Stacked Tanks	1	2	3	4	1	2	3	4	1	2	3
Gallon Capacity	35	35/35	35/35/35	35/35/35/35	70	70/70	70/70/70	70/70/70/70	120	120/120	120/120/120
System Height	37"H	47"H	57"H	67"H	47"H	67"H	87"H	107"H	59"H	91"H	123"H
Gravity Feed Kit	GFKIT1	GFKIT2	GFKIT3	GFKIT4	GFKIT1	GFKIT2	GFKIT3	GFKIT4	GFKIT1	GFKIT2	GFKIT3

Large Tote-A-Lube Gravity Feed Systems 130, 180, 240 & 330 Gallon Tanks

Includes: Tank(s), 24"H Stand, Drip Tray Assembly and Gravity Feed Dispense Kit. 43"W x 54"D Assembled.	130 Gallon				180 Gallon			240 Gallon		330 Gallon
										
Part No.	T130-1	T130-2	T130-3	T130-4	T180-1	T180-2	T130-180-180	T240-1	T240-2	T330-1
No. of Stacked Tanks	1	2	3	4	1	2	3	1	2	1
Gallon Capacity	130	130/130	130/130/130	130/130/130/130	180	180/180	130/180/180	240	240/240	330
System Height	50"H	73"H	96"H	119"H	59"H	91"H	105"H	69"H	111"H	83"H
Gravity Feed Kit	GFKIT1	GFKIT2	GFKIT3	GFKIT4	GFKIT1	GFKIT2	GFKIT3	GFKIT1	GFKIT2	GFKIT1
										Note: System Includes Support Hoop

System Accessories			Mobile Bases, Casters and Caster Kits		
	SS	Base, 32"W x 32"D		LSJ30	Jobber Cage 30"H for T180/T240/T330 Tanks
	LS	Base, 42"W x 42"D			
	SS024	Stand, Small 24"H, 32"W x 32"D			
	SS036	Stand, Small 36"H, 32"W x 32"D		SSFP	32"W x 32"D Steel Forklift Base with Leg Coupling
	LS024	Stand, Large 24"H, 42"W x 42"D		LSFP	42"W x 42"D Steel Forklift Base with Leg Coupling
	LS036	Stand, Large 36"H, 42"W x 42"D		SSC8	32"W x 32"D Steel Base with 8" Caster Kit & Tabs
	LSSS	Leg Support Brace 32"W x 32"D		LSC8	42"W x 42"D Steel Base with 8" Caster Kit & Tabs
	LLSL	Leg Support Brace 42"W x 42"D		LCA	Caster Plates, Set of (4). Use with Standard Base.
	35300948	Leg, Threaded 4"H (Ea.)		LCAE	Extended Caster Plates Set of (4). Use with Forklift Base.
	35300949	Leg, Threaded 10"H (Ea.)		LCK8	Caster Kit, with Plates (2) 8" Straight, (2) 8" Braking. For Standard Base.
	35300950	Leg, Threaded 14"H (Ea.)		LC8S	8" Caster Wheel, Straight
	35300951	Leg, Threaded 24"H (Ea.)		LC8B	8" Caster Wheel, Braking
	35300952	Leg, Threaded 36"H (Ea.)			
	L1.524WLP	Leg with Leg Plate Kit 24"H Welded-On Floor Securement Plate.	Secondary Containment Vessels		
	L1.536WLP	Leg with Leg Plate Kit 36"H Welded-On Floor Securement Plate.		CV150	150 Gallon Poly Vessel. Use with T35, T70, T120, all Wall-Stackers. 40"W x 52"D x 23"H, 40 Lbs.
	LEG-PLATE-KIT	Leg Plate Kit Bolt Legs to Floor, (4) Plates		CV265	265 Gallon Poly Vessel. Use with T130, T180, T240. 48"W x 66"D x 24"H, 60 Lbs.
	TAB1	Tabs, Set of (2) ULC Required. Bolt onto Stand, Secures Tank.		CV85S	85 Gallon Steel Vessel. Use with T70. 38"W x 47"D x 11"H, 107 Lbs.
	CBR	Conversion Bracket Secures a 32" Tank on top of a 42" Tank		CV150S	150 Gallon Steel Vessel. Use with T120. 36"W x 48"D x 22"D, 132 Lbs.
	HWSS	Wall Straps Use with 32" Tanks		CV275S	275 Gallon Steel Vessel. Use w/ T130, T180, T240. 46"W x 56"D x 25"H, 174 Lbs.
	HWSL	Wall Straps Use with 42" Tanks		CV375S	375 Gallon Steel Vessel. Use with T330. 46"W x 56"D x 34"H, 254 Lbs.
	DTHS	Drip Tray Assy (Frame, 4-Pans, 4-Screens)		CV210S	210 Gallon Steel Vessel. Use with T180. Forklift Ready with 5" Legs. 46"W x 46"D x 29"H, 150 Lbs.
	DTHL	Drip Tray Assy (Frame, 5-Pans, 5-Screens)		CV270S	270 Gallon Steel Vessel. Use with T240. Forklift Ready with 5" Legs. 46"W x 46"D x 35"H, 185 Lbs.
	DPTH	Drip Tray Frame (Steel) Use with 32" Tanks		CV370S	370 Gallon Steel Vessel. Use with T330. Forklift Ready with 5" Legs. 46"W x 46"D x 46"H, 231 Lbs.
	DPTH	Drip Tray Frame (Steel) Use with 42" Tanks			
	SCTDTPS	Drip Tray Insert with Screen			

Gravity Feed Kits, Valves, Filters & Components

Gravity Feed Kits with Stainless Steel Valves								Remote Fill Kit
Sealant Included	Spring Release Valve	Elbow Mount	90° Poly Elbow	Poly Tubing	Hose Clamps	1" Poly Stub Barb	RFKIT1	
	GFKIT1	1	-	-	-	-	Includes 8' Hose, Tank Adapter, Ball Valve, 1.5" Cam Fitting with Cover, Hose Clamps, & Breather. NOT INCLUDED: Tanks and Accessories. Use with (1) Tank.	
	GFKIT2	2	1	1	4'	2		
	GFKIT3	3	2	2	9'	4		
	GFKIT4	4	3	3	15'	6		
	GFKITADD1	1	1	1	7'	2		
Gravity Feed Kits with Stainless Steel Valves & Elbows								
	GFKITSS1	1	-	-	-	-		
	GFKITSS2	2	1	1	4'	2		
	GFKITSS3	3	2	2	9'	4		
	GFKITSS4	4	3	3	15'	6		
	GFKITSSADD1	1	1	1	7'	2		
Valves			Components					
	35400436	316SS Stainless Steel Spring Release Valve, 1" MNPT		EBM	Elbow Mounting Bracket, Includes Bolt and Hose Barb			
	SSBV1ASSEM	1" Stainless Steel Valve 1"NPT and 1" Barbed Fitting		SSEBM	Stainless Steel Elbow Mounting Bracket, Includes Bolts			
	BBV1	1" Brass Ball Valve Assy with 90° Barb and 1" Brass Nipple		34100542	Barb, Poly Fitting, 90° 1" MNPT			
	BBV	1" Brass Ball Valve 1"F x 1"F NPT No Fittings		61305	Barb, Poly Straight Stud 1" MNPT			
	PV	1" Poly Ball Valve w/ Nipple, 90° Fitting		SPN1	Pipe Nipple Steel, 1"MPT			
	BBV3FPORTL1	3 Way Ball Valve 1" L Port with 1" FNPT		PTFT	Tubing, 1" Clear Poly Per Foot			
				PTBX100	Tubing, 1" Clear Poly 100' Roll			
				BHRKIT1	Bulkhead Replacement Kit Includes: Bulkhead, Retention Ring, Sealant and Screws			
				34300458	Cap 2", Plastic Used In Fill Port			
				35900863	Top Steel Plug with Buna Gasket, 2in			
				VCGM2	Vent Cap 2" NPT			
				62257	Poly Plug, 1" For Bulkhead Fitting			
				DTM18404001B	Double Tapp 2"MPT x 1"FPT			
				MHC1	Hose Clamp, Stainless Steel			
				REC5	Rector Sealant			
				99300085	Tru-Blu Pipe Thread Sealant (1 3/4 Oz. Tube)			
Filters, Holder and Kits								
	AFAS	Filter Kit FD101 & 45° Holder						
	FD101	Air Sentry Filter 5" x 5", 1" Slip Fit						
	FD108	Air Sentry Filter 5" x 10", 2" MNPT						
	FHK45	Filter Holder, 45° for Fill Port						
	FHK90	Filter Holder, 90° for Fill Port						
	FHK	Filter Holder, In Cap						

Wall-Stacker Stackable Tanks, Gravity Feed Systems & Accessories

Wall-Stacker Tanks 32, 71 and 115 Gallons

Wall-Stacker Tanks			
Part No.	WS32	WS71	WS115
Tank Capacity	32 Gallons	71 Gallons	115 Gallons
Tank Dimensions	38"W x 19"D		
Tank Height	18"H	33"H	48"H
Tank Weight	33 Lbs.	47 Lbs.	61 Lbs.

(2) Angled Fill Port with 2" NPT Poly Cap

(2) Molded Grooves for Wall Straps









1" NPT Stainless Steel Dispense Fitting



Wall-Stacker Gravity Feed Systems

Gravity Feed Systems Include: Tank(s), 24"H Stand, Drip Tray Assembly, Wall Straps and Gravity Feed Dispense Kit. 38"W x 30"D Assembled.	32 Gallon				71 Gallon			115 Gallon	
									
Part No.	WS32-1	WS32-2	WS32-3	WS32-4	WS71-1	WS71-2	WS71-3	WS115-1	WS115-2
No. of Stacked Tanks	1	2	3	4	1	2	3	1	2
Gallon Capacity	32	32/32	32/32/32	32/32/32/32	71	71/71	71/71/71	115	115/115
System Height	42"H	57"H	72"H	87"H	57"H	87"H	117"H	72"H	117"H
Wall Straps No.	VWS15	VWS30	VWS45	VWSA	VWS30	VWSA	VWSA	VWS45	VWSA
Gravity Feed Kit	GFKIT1	GFKIT2	GFKIT3	GFKIT4	GFKIT1	GFKIT2	GFKIT3	GFKIT1	GFKIT2

Wall-Stacker System Accessories

	SW	Base, Steel 6"H with Leg Coupling		CV150	150 Gallon Poly Vessel. Use with T35, T70, T120, all Wall-Stackers. 40"W x 52"D x 23"H, 40 Lbs.
	SW24	Stand, Steel, 24"H			
	SW36	Stand, Steel, 36"H			
	DTHS	Drip Tray Assy (Frame, 4-Pans, 4-Screens)		Wall Straps	17"H For WS32-1
	DPTHs	Drip Tray Frame (Steel)			32"H For WS32-2, WS71-1
	SCTDTPS	Drip Tray Insert with Screen			47"H For WS32-3, WS115-1
					Adjustable: 60"H, 75"H or 90"H For WS32-4, WS71-2, WS71-3 and WS115-2



Slimtainer Stackable Tanks, Gravity Feed Systems & Accessories

Slimtainer Tanks 120 Gallons

Slimtainer Tanks	
Part No.	1035501N95401
Tank Capacity	120 Gallons
Tank Dims.	54"W x 22"D
Tank Height	32"H
Tank Weight	70 Lbs.

2" Top Opening

Interlocking Top & Bottom Points for Secure Stacking

2" Fill Opening

Molded Internal Pass Through Holes Suppress Bulging & Adds Strength and Stability



(3) Molded-In Stainless Steel 1" NPT Inserts - (1) on Each Side & (1) on the Front

Slimtainer Gravity Feed Systems

All Slimtainer Gravity Feed Systems Include: Tank(s), 24"H Stand and 316SS Spring Valves and Gravity Feed Kit. Also Included is the Drip Tray Assembly OR Containment Vessel.	Includes Stand/Drip Tray Assy.		Includes Stand/Containment	
Part No.	SST120-1	SST120-2	SST120-1CV	SST120-2CV
No. of Stacked Tanks	1	2	1	2
Gallon Capacity	120	120/120	120	120/120
Assembled Dims.	64.5"W x 23"D x 56"H	64.5"W x 23"D x 84"H	74"W x 24.5"D x 56"H	74"W x 24.5"D x 84"H
Features	Drip Tray Assembly	Drip Tray Assembly	145 Gallon Poly Containment Vessel	145 Gallon Poly Containment Vessel

Slimtainer System Accessories

	SSTEBM	Slimtainer Elbow Bracket Kit		SSTDTA	Slimtainer Drip Tray Assembly (Frame, 2-Pans, 2-Screens)
	SCTEBM	Tank Stand Elbow Kit		34702870	Slimtainer Drip Tray Frame
	34901362	Slimtainer Steel Base		35400436	316SS Stainless Steel Spring Release Valve
	SSTSL24	Slimtainer Steel Stand with 24" Legs		SCTGFKIT2	2 Tank Gravity Feed Kit Includes 1" Tubing, Hose Connectors, Hose Clamps, Sealant & Elbow Kit
	1035600N97801	145 Gallon Poly Vessel with Sump. 74"W x 24.5"D x 22.5"H			



Cubetainer Stackable Tanks

Cubetainer Tanks 60, 80, 120, 180 and 260 Gallons

2" Top Opening for Pump or Vent Application

1" Opening for Desiccant Breather or Remote Fill

80, 120, 180 & 260 Gallon Tanks
(6) 3/8-16 Molded-In Inserts Secures Side Mount Pump Plate (Optional)

(2) Molded-In Stainless Steel 1" NPT Insert at Drain Openings

Interlocking Top and Bottom Ridges for Secure Stacking

Convenient 2" Center Fill Opening

120, 180 & 260 Gallon Tanks
(4) 1/4-20 Molded Inserts on Front Surface

Molded-In and Inked Site Gauge in Gallons and Liters, and Semi-Transparent Material, Eliminates the Need for External Site Gauges



60 Gallon Tank



80 Gallon Tank



120 Gallon Tank



180 Gallon Tank



260 Gallon Tank

Cubetainer Tanks					
Part No.	1032003N95401	1032103N95401	1032203N95401	1032303N95401	1032403N95401
Tank Capacity	60 Gallons	80 Gallons	120 Gallons	180 Gallons	260 Gallons
Tank Dimensions	36"W x 36"D	36"W x 36"D	36"W x 36"D	36"W x 36"D	36"W x 36"D
Tank Height	17 1/2 "H	21 3/4 "H	30 1/2 "H	44" H	57 1/4" H
Tank Weight	44 Lbs.	50 Lbs.	63 Lbs.	105 Lbs.	185 Lbs.



Optional Container Pallet is forklift & pallet jack accessible and compatible with all sizes and stand configurations. This corrosion resistant polyethylene base allows you to move the Cubetainer or load them onto trucks as well as stack on top of other Cubetainers. See Container Pallet Page 12.



Gravity Feed Systems

<p>Includes: Tank(s), 24"H Stand, Drip Tray Assembly and Gravity Feed Dispense Kit.</p> <p>36"W x 48"D Assembled.</p>							
	Part No.	SCT60-3	SCT60-4	SCT80-2	SCT80-3	SCT80-4	
	No. of Stacked Tanks	3	4	2	3	4	
	Gallon Capacity	60/60/60	60/60/60/60	80/80	80/80/80	80/80/80/80	
	System Height	70"H	83"H	65"H	83"H	100"H	
<p>Includes: Tank(s), 24"H Stand, Drip Tray Assembly and Gravity Feed Dispense Kit.</p> <p>36"W x 48"D Assembled.</p>							
	Part No.	SCT120-1	SCT120-2	SCT120-3	SCT180-1	SCT180-2	SCT260-1
	No. of Stacked Tanks	1	2	3	1	2	1
	Gallon Capacity	120	120/120	120/120/120	180	180/180	260
	System Height	56.5"H	83"H	108"H	70"H	108"H	83"H
<p>Includes: Tank(s), 24"H Stand, Drip Tray Assembly and Gravity Feed Dispense Kit.</p> <p>36"W x 48"D Assembled.</p>							
	Part No.	SCT60-60-120	SCT60-60-180	SCT80-120	SCT80-80-120	SCT80-120-120	SCT120-180
	No. of Stacked Tanks	3	3	2	3	3	2
	Gallon Capacity	60/60/120	60/60/180	80/120	80/80/120	80/120/120	120/180
	System Height	83"H	95"H	74"H	91.5"H	100.5"H	95"H



Cubetainer System Accessories

Gravity Feed Kits		Containment Vessels & Pallets	
	SCTGFKIT2	2 Tank Gravity Feed Kit Includes: 1" Tubing, Hose Connectors, Hose Clamps, Sealant & Elbow Kit	1032500N97801 203 Gallon Poly Vessel 52"W x 58"D x 20"H, 65 Lbs.
	SCTGFKIT3	3 Tank Gravity Feed Kit Includes: 1" Tubing, Hose Connectors, Hose Clamps, Sealant & Elbow Kit	1007900N97801 390 Gallon Poly Vessel 62"W x 76"D x 28"H, 130 Lbs.
	SCTGFKIT4	4 Tank Gravity Feed Kit Includes: 1" Tubing, Hose Connectors, Hose Clamps, Sealant & Elbow Kit	1031900M76400 Cubetainer Pallet , 40 Lbs. 34702273 Pallet Attachment Kit
Stands & Mobile Bases		Dispense Accessories	
	35801577	Steel Base	35400436 316SS Stainless Steel Spring Release Valve
	SCTSL04	Steel Stand with 4" Legs	SCTRFKIT1 Remote Fill Kit Includes Top Connection Fittings, 1" Fill Hose, 1" Brass Ball Valve, 1" Male Camlock Fill Connection, Dust Cap & Leg Bracket. (Bottom Fill Connection Brackets to Stand Leg.) NOT INCLUDED: Tanks & System.
34702280	Steel Stand with 10" Legs		
	SCTSL14	Steel Stand with 14" Legs	35801582 Universal Pump Wall Mount Bracket
	SCTSL24	Steel Stand with 24" Legs	SMPB Pump Shelf (Steel), Side Mount Use w/ Large Tote-A-Lube Tanks and Cubetainer Tanks (Excluding 60 Gal. Cubetainer).
SCTSL36	Steel Stand with 36" Legs		
	35300948	Leg, 4" Threaded	SMTS Pump/Reel Shelf (Steel), Side Mount Use w/ Large Tote-A-Lube Tanks and Cubetainer Tanks (Excludes 60 Gal. Cubetainer).
	35300949	Leg, 10" Threaded	
	35300950	Leg, 14" Threaded	
	35300951	Leg, 24" Threaded	
	35300952	Leg, 36" Threaded	SCTPLAC 1824 Placard for Fluid Identification, 18" X 24"
	SCTEBM	Tank Stand Elbow Kit	SCTSMPK Pump Inlet Plumbing Kit, 1"
	SCTCK8	8" Caster Kit with Plates (2) 8" Straight, (2) 8" Braking (4) Plates. Use with Steel Base & 60, 80, 120 Gallon Cubetainers.	35400365 Brass Ball Valve, 1" F x 1" M NPT
			34100542 1in Poly Elbow
	61305	1in Poly Straight Fitting	PTFT Tubing, 1" Clear Poly Per Foot
	LC8S	8" Caster Wheel, Straight	MHC1 Hose Clamp
	LC8B	8" Caster Wheel with Brake	99300085 Tru-Blu Pipe Thread Sealant (1 3/4 Oz. Tube)
	34702395	(4) Attachment Plates with Bolt Kits	35902895 Desiccant Air Breather
Drip Tray & Accessories		34300457 1-Way Breather Cap, 2"	
	34702385	Drip Tray Frame with Bolt Kit	34300458 Top Fill Plug, Polyethylene, 2" White
	SCTDTPS	Drip Tray Insert with Screen	35900863 Top Steel Plug with Buna Gasket, 2"
	SCTDTA	Drip Tray Assembly (Frame, 4-Pans, 4-Screens)	62257 Bottom Drain Plug, 1in Black



Roth Double Wall Tanks

Double Wall Construction for Ultimate Safety & Reliability

Construction

- The outer tank is made of leak-proof, weld-free galvanized steel and is roll-seamed with an oil and fire-resistant seal. It can contain up to 110% of the capacity of the inner tank for maximum protection.
- The inner tank is made of blow-molded, high-density, seamless polyethylene that is leak proof and will never corrode.

Double Wall Benefits

- Use for Class II and Class III fluids including: heating oil, motor and gear oil, hydraulic fluids, ATF, brake or power steering fluids, ethylene or propylene glycol based anti-freezes, diesel and bio fuels.
- Outer tank holds 110% of inner tank for maximum protection.
- Compact, economical design with (4) 2"NPT Openings (8 sq. ft for 275 gallon).
- Up to 50% lighter than a 12-gauge steel tank with larger storage capacity.
- Zero fittings below the fluid line.
- Wide handles allow easy handling.
- Leak-proof and will not corrode.













Certified to UL SU2258 and designed to store liquids that are classified as class II or class III combustibles. Roth Double Wall Tanks are compliant with NFPA 30 & 30A, subject to building code approval by a local authority having jurisdiction.

Roth Tanks		Roth Tank Plus Packages					
	Each Roth Double Wall Tank has an Optical Leak Alarm & (4) 2"NPT Openings.			Roth Double Wall Tank w/ Optical Leak Alarm, Level Gauge & Lockable Fill Cap with Vent.			
	Part No.	Capacity		Dimensions	Part No.	Capacity	Dimensions
	DWT110	110 Gallons		28"W x 29"D x 48"H	DWT110A	110 Gallons	28"W x 29"D x 52"H
	DWT165	165 Gallons		28"W x 29"D x 65"H	DWT165A	165 Gallons	28"W x 29"D x 69"H
	DWT275	275 Gallons		28"W x 43"D x 65"H	DWT275A	275 Gallons	28"W x 43"D x 69"H
	DWT275LH	275 Gallons		30"W x 51"D x 58"H	DWT275LHA	275 Gallons	30"W x 51"D x 62"H
DWT400	400 Gallons	30"W x 64"D x 72"H	DWT400A	400 Gallons	30"W x 64"D x 76"H		













Roth Double Wall Tank Packages

Roth Tank & Fluidall Exclusive Pump Packages				
		Roth Double Wall Tank, Fluidall Exclusive Dispense Package (3:1 T312 Pump, Industrial Grade Hose Reel with 50' Hose, M3 Preset/Non-Preset Meter, Air Pressure Regulator), Fluid Level Gauge, Lockable Fill Cap w/ Vent, Down Tube, Mounting Bracket.		
	DWT110FP with Preset Meter	DWT110FM with Manual Meter	110 Gallons	28"W x 29"D x 68"H
	DWT165FP with Preset Meter	DWT165FM with Manual Meter	165 Gallons	28"W x 29"D x 85"H
	DWT275FP with Preset Meter	DWT275FM with Manual Meter	275 Gallons	28"W x 43"D x 85"H
	DWT275LHFP with Preset Meter	DWT275LHFM with Manual Meter	275 Gallons	30"W x 51"D x 78"H
	DWT400FP with Preset Meter	DWT400FM with Manual Meter	400 Gallons	30"W x 64"D x 92"H
Roth Tank & Samson Pump Packages				
		Roth Double Wall Tank, Samson Dispense Package (3:1 Pump Master Oil Pump, Hose Reel with 50' Hose, Preset or Non-Preset Meter, Air Pressure Regulator), Fluid Level Gauge, Lockable Fill Cap with Vent, Down Tube, Mounting Bracket.		
	DWT110P-S with Preset Meter	DWT110M-S with Manual Meter	110 Gallons	28"W x 29"D x 68"H
	DWT165P-S with Preset Meter	DWT165M-S with Manual Meter	165 Gallons	28"W x 29"D x 85"H
	DWT275P-S with Preset Meter	DWT275M-S with Manual Meter	275 Gallons	28"W x 43"D x 85"H
	DWT275LHP-S with Preset Meter	DWT275LHM-S with Manual Meter	275 Gallons	30"W x 51"D x 78"H
	DWT400P-S with Preset Meter	DWT400M-S with Manual Meter	400 Gallons	30"W x 64"D x 92"H
Roth Tank & Graco Pump Packages				
		Roth Double Wall Tank, Graco Dispense Package (3:1 LD Pump, SD Reel with 50' Hose, Preset LD Meter or Manual EM Meter, Air Pressure Regulator), Down Tube, Fluid Level Gauge, Lockable Fill Cap with Vent, Mounting Bracket.		
	DWT110P with Preset Meter	DWT110M with Manual Meter	110 Gallons	28"W x 29"D x 68"H
	DWT165P with Preset Meter	DWT165M with Manual Meter	165 Gallons	28"W x 29"D x 85"H
	DWT275P with Preset Meter	DWT275M with Manual Meter	275 Gallons	28"W x 43"D x 85"H
	DWT275LHP with Preset Meter	DWT275LHM with Manual Meter	275 Gallons	30"W x 51"D x 78"H
	DWT400P with Preset Meter	DWT400M with Manual Meter	400 Gallons	30"W x 64"D x 92"H
Roth Tank & Fire-Ball Dispense Packages				
		Roth Double Wall Tank, Graco Dispense Pkg (5:1 Fire-Ball 300 Pump, SD Reel with 50' Hose, SD Digital Meter, Air Pressure Regulator), Down Tube, Fluid Level Gauge, Lockable Fill Cap with Vent, Pump/ Reel Bracket.		
	DWT110FBP with Preset Meter	DWT110FBM with Manual Meter	110 Gallons	28"W x 29"D x 68"H
	DWT165FBP with Preset Meter	DWT165FBM with Manual Meter	165 Gallons	28"W x 29"D x 85"H
	DWT275FBP with Preset Meter	DWT275FBM with Manual Meter	275 Gallons	28"W x 43"D x 85"H
	DWT275LHFBP with Preset Meter	DWT275LHFBM with Manual Meter	275 Gallons	30"W x 51"D x 78"H
	DWT400FBP with Preset Meter	DWT400FBM with Manual Meter	400 Gallons	30"W x 64"D x 92"H
Roth Tank & Fire-Ball Pump Only Packages				
		Roth Double Wall Tank, Graco 5:1 Fire-Ball 300 Pump, Air Pressure Regulator, Down Tube, Fluid Level Gauge, Lockable Fill Cap with Vent, Mounting Bracket.		
	DWT110FBPO		110 Gallons	28"W x 29"D x 61"H
	DWT165FBPO		165 Gallons	28"W x 29"D x 79"H
	DWT275FBPO		275 Gallons	28"W x 43"D x 79"H
	DWT275LHFBPO		275 Gallons	30"W x 51"D x 72"H
	DWT400FBPO		400 Gallons	30"W x 64"D x 86"H

Roth recommends either using a Roth Tie-Down Kit (pg. 16) or securing all Roth Tanks & Pump Packages to a wall.



Roth Double Wall Tank Packages

Roth Tank & Graco Oil Tap Packages				
		Roth Double Wall Tank with Single Oil Tap Package (Graco LD 3:1 Pump, Metered or Non-Metered Single Tap Oil Bar with Dispense Valve, Hose, Air Pressure Regulator) Down Tube, Fluid Level Gauge, Lockable Fill Cap with Vent.		
	DWT110OTM Metered	DWT110OT Non-Metered	110 Gallons	28"W x 29"D x 54"H
	DWT165OTM Metered	DWT165OT Non-Metered	165 Gallons	28"W x 29"D x 71"H
	DWT275OTM Metered	DWT275OT Non-Metered	275 Gallons	28"W x 43"D x 71"H
	DWT275LHOTM Metered	DWT275LHOT Non-Metered	275 Gallons	30"W x 51"D x 64"H
	DWT400OTM Metered	DWT400OT Non-Metered	400 Gallons	30"W x 64"D x 78"H
Roth Tank & Graco Diaphragm Metered Packages				
		Roth Double Wall Tank, Graco Dispense Package (Husky 1050 Double Diaphragm Pump, SD Reel with 50' Hose, Meter, Air Pressure Regulator), Down Tube, Fluid Level Gauge, Lockable Fill Cap with Vent, Pump/Reel Bracket.		
	DWT110DDP with Preset Meter	DWT110DDM with Manual Meter	110 Gallons	28"W x 29"D x 68"H
	DWT165DDP with Preset Meter	DWT165DDM with Manual Meter	165 Gallons	28"W x 29"D x 85"H
	DWT275DDP with Preset Meter	DWT275DDM with Manual Meter	275 Gallons	28"W x 43"D x 85"H
	DWT275LHDDP with Preset Meter	DWT275LHDDM with Manual Meter	275 Gallons	30"W x 51"D x 78"H
	DWT400DDP with Preset LD Meter	DWT400DDM with Manual Meter	400 Gallons	30"W x 64"D x 92"H
Roth Tank & Graco Waste Oil Packages				
		Roth Double Wall Tank, Graco 1050 Husky Double Diaphragm Pump, Large Funnel, Hose Kit, Fluid Level Gauge and Pump/Reel Bracket.		
	DWT110WO		110 Gallons	28"W x 29"D x 68"H
	DWT165WO		165 Gallons	28"W x 29"D x 85"H
	DWT275WO		275 Gallons	28"W x 43"D x 85"H
	DWT275LHWO		275 Gallons	30"W x 51"D x 78"H
	DWT400WO		400 Gallons	30"W x 64"D x 92"H
Roth Tank & Samson Anti-Freeze Pump Packages				
		Roth Double Wall Tank, with Samson Dispense Package (1:1 Samson Pump, 50' Hose Reel, Non-Metered Control Handle, Air Pressure Regulator) Down Tube, Fluid Level Gauge, Lockable Fill Cap with Vent, Pump/Reel Bracket.		
	DWT110SCP		110 Gallons	28"W x 29"D x 68"H
	DWT165SCP		165 Gallons	28"W x 29"D x 85"H
	DWT275SCP		275 Gallons	28"W x 43"D x 85"H
	DWT275LHSCP		275 Gallons	30"W x 51"D x 78"H
	DWT400SCP		400 Gallons	30"W x 64"D x 92"H
Roth Tank & Graco Anti-Freeze Pump Packages				
		Roth Double Wall Tank, with Graco Dispense Package (Husky 716 DDP, 50' Hose Reel, Non-Metered Control Handle, Air Pressure Regulator), Manifold Kit, Fluid Level Gauge, Lockable Fill Cap with Vent, Pump/Reel Bracket.		
	DWT110GDCP		110 Gallons	28"W x 29"D x 68"H
	DWT165GDCP		165 Gallons	28"W x 29"D x 85"H
	DWT275GDCP		275 Gallons	28"W x 43"D x 85"H
	DWT275LHGDCP		275 Gallons	30"W x 51"D x 78"H
	DWT400GDCP		400 Gallons	30"W x 64"D x 92"H

Roth recommends either using a Roth Tie-Down Kit (pg. 16) or securing all Roth Tanks & Pump Packages to a wall.



Roth Double Wall Tank Accessories

	Mounting Brackets			Fluid Level Gauges		
	Pump / Reel Bracket Includes Gun Holder, Drip Cup & Mounting Hardware			Not Suitable for Use with DEF.		
	DWTRB	Use with DWT110, DWT165 or DWT275		DWTFGL110	Use with DWT110	
	DWTRB400	Use with DWT275LH or DWT400	DWTFGL275	Use with DWT165 or DWT275		
	Fire-Ball Pump / Reel Bracket Includes Gun Holder, Drip Cup & Mounting Hardware			High Level Tank Alarm		
	DWTFBPPB	Use with DWT110, DWT165 or DWT275		TAHPP10	10" Adjustable Working Depth with 2" NPT Bung Adapter	
	DWTFBPPB400	Use with DWT275LH or DWT400				
	Fire-Ball Pump Bracket Includes Bung Adapter & Mounting Hardware			Lockable Fill Cap w/ Vent		
	DWTFBNR	Use with DWT110, DWT165 or DWT275		DWTFVCV		
	DWTFB400NR	Use with DWT275LH or DWT400				
	HD Pump Bracket Adapter with 2" Thread			10" Drain Funnel with Lid		
	DWTFBPPB2T	Use with DWTMPB, DWTFBPPB, DWTFBPPB400, DWTFBNR, or DWTFB400NR		DF10		
	Pump Bracket Manifolds (2) Roth Double Wall Tanks Together			Tie-Down Kits		
	DWTMPB	Use with (2) Tanks of the same height.		DWTTDK110	Use with DWT110	
	Mobile Cages, Fully Welded			Tank Covers		
	Steel Cage with 8" Casters and Fork Pockets Includes Ergonomic Handle			DWTCOV110/165	Use with DWT110 or DWT165	
	DWTPCG110	Use with DWT110		DWTCOV275	Use with DWT275	
	DWTPCG275LH	Use with DWT275LH	DWTCOV275LH	Use with DWT275LH		
	Steel Cage with Fork Pockets (Casters Not Available)			Duplex Bushings		
	DWTCG165	Use with DWT165		DWTDDB12	1/2" with Fittings	
	DWTCG275	Use with DWT275		DWTDDB38	3/8" with Fittings	
	DWTCG400	Use with DWT400		Vent Alarm		
	Oil Bars and Kits			DWTV2		
	Single Tap Oil Bar			2" NPT		
	FHDKOT1	Includes (1) Dispense Valve				
	Single Tap Oil Bar Kit Includes Graco LD 3:1 Pump and Hose					
	FHDKOT1KIT1M	Metered				
	FHDKOT1KIT1	Non-Metered (Shown)				
	Manifold Kits					
	Manifold Kits Require Pump and Additional Fittings					
	DWTMANKIT1	Adds (1) Double Wall Tank				
	DWTMANKIT2	Joins (2) Double Wall Tanks				

Hybrid Double Wall Cart

Outer Steel Containment Encases a 110 Gallon Poly Tank

This mobile low profile Hybrid Double Wall Cart offers the advantage of bulk fluid delivery and provides a practical alternative to fixed fluid storage areas. Available with reliable fluid handling equipment packages. Easily push the Hybrid Cart to the point-of-dispense; it's never been easier to store and dispense automotive style fluids around the shop.

The Hybrid Double Wall Cart has (4) 2"NPT openings and features a built-in universal reel mount. The outer steel tank layer is fully-welded with a stable ergonomic handle, low profile mount 5" caster wheels and a powder coated finish. The Hybrid Cart can contain up to 110% of the capacity of the inner 110 gallon poly tank.



Level Gauge & Lockable Fill Cap are NOT Shown.

Hybrid Double Wall Cart	
HDWT110-1A	Includes 110 Gallon Double Wall Cart with Universal Reel Mount, Ergonomic Handle, 5" Casters, Level Gauge and Lockable Fill Cap with Vent. Dimensions: 27.5" x 42" x 41"H.
Double Wall Steel Cart Packages	
Fluidall Exclusive Dispense Package, Premium Preset Meter	
HDWT110-1FP	Includes Level Gauge, Lockable Fill Cap with Vent, and Fluidall Exclusive Preset Pump Package (Fluidall Exclusive 3:1 T312 Oil Pump, 50' Industrial Grade Hose Reel, M3 Preset Meter, Air Pressure Regulator, and Down Tube).
Fluidall Exclusive Dispense Package, Premium Manual (Non-Preset) Meter	
HDWT110-1FM	Includes Level Gauge, Lockable Fill Cap with Vent, and Fluidall Exclusive Non-Preset Pump Package (Fluidall Exclusive 3:1 T312 Oil Pump, 50' Industrial Grade Hose Reel, M3 Non-Preset Meter, Air Pressure Regulator, and Down Tube).
Samson Dispense Package, Premium Preset Meter	
HDWT110-1SP	Includes Level Gauge, Lockable Fill Cap with Vent, and Samson Preset Pump Package (Samson 3:1 PumpMaster Oil Pump, Samson 50' Reel, Samson Preset Meter, Air Pressure Regulator, and Down Tube).
Samson Dispense Package, Premium Manual (Non-Preset) Meter	
HDWT110-1SM	Includes Level Gauge, Lockable Fill Cap with Vent, and Samson Non-Preset Pump Package (Samson 3:1 PumpMaster Oil Pump, Samson 50' Reel, Samson Non-Preset Meter, Air Pressure Regulator, and Down Tube).
Graco Dispense Package, Premium Preset Meter	
HDWT110-1GP	Includes Level Gauge, Lockable Fill Cap with Vent, and Graco Preset Pump Package (Graco LD 3:1 Pump, Graco SDX 50' Reel, Graco Preset Gun, Air Pressure Regulator, Down Tube).
Graco Dispense Package, Premium Manual (Non-Preset) Meter	
HDWT110-1GM	Includes Level Gauge, Lockable Fill Cap with Vent, and Graco Non-Preset Pump Package (Graco LD 3:1 Pump, Graco SDX 50' Reel, Graco Non-Preset Gun, Air Pressure Regulator, Down Tube).



Optional Samson Dispense Package, Premium Preset Meter Shown

Single Wall Steel Tanks

Manufactured with the UL-142 Regulations in Mind

Single Wall Steel Tanks				Optional Accessories			
Tank Features: Top Mounted Diaphragm Pump/Reel Bracket and Built-In Bracket for Gun Holder/Placard Insert. Tank Openings: (4) 2" Top NPT, (1) 4" Top NPT, and (1) 1" Steel Dispense Fitting							
	SSW200	200 Gallons	32"W x 32"D x 46"H		SSWL60	Fluid Level Gauge	Use with SSW200, SSW280, SSW315
	SSW315	315 Gallons	40"W x 40"D x 46"H		FLG007600	Black Knight Liquid Level Gauge, 99"	For Use with all Steel Tanks up to 99", for Oil, Waste Oil, Diesel Fuel, Antifreeze. Features a Horizontal Float and 2" NPT Threads.
	SSW400	400 Gallons	40"W x 40"D x 64"H				
	SSW280	280 Gallons	60"W x 24"D x 45"H		DWTFCV	Lockable Fill Cap with Vent	Use with All Tanks
					35400436	316SS Stainless Steel Spring Release Valve, 1" MNPT	Use with SSW200, SSW315, SSW400

Single Wall Steel Tank Plus Packages

Cost-Effective Steel Tanks with Gravity Feed Dispense

Single Wall Steel Tank Plus Packages			
	Includes: Steel Tank, 24"H Stand, Drip Tray Assembly, Fluid Level Gauge, Lockable Fill Cap with Vent and Gravity Feed Valve. Tank Openings: (4) 2" Top NPT, (1) 4" Top NPT, and (1) 1" Steel Bulkhead		
	SSW200A	200 Gallons	36"W x 44"D x 70"H
	SSW315A	315 Gallons	44"W x 54"D x 70"H
	SSW400A	400 Gallons	44"W x 54"D x 88"H



SSW200A Tank Plus Package Shows Top of Tank with Built-In Reel Bracket, (1) 4" NPT Opening, (4) 2" NPT Openings with Lockable Fill Cap with Vent & Fluid Level Gauge.

Single Wall Steel Tank Packages

Easy-To-Order, Complete Steel Storage & Dispense Packages



SSW280FP with Fluidall Exclusive Preset Package Shown











SSW200GP, SSW400GP, and SSW315GP with Graco Dispense Packages Shown

Fluidall Exclusive Dispense Package, Premium Preset Meter				
SSW200FP	200 Gallons	SSW400FP	400 Gallons	Includes 24"H Stand*, Level Gauge, Lockable Fill Cap with Vent, Tank Mounted Gun Holder, and Fluidall Exclusive Preset Pump Package (Fluidall Exclusive 3:1 T312 Oil Pump, 50' Industrial Grade Hose Reel, M3 Preset Meter, Air Pressure Regulator, and Down Tube).
SSW315FP	315 Gallons	SSW280FP	280 Gallons	
Fluidall Exclusive Dispense Package, Premium Manual (Non-Preset) Meter				
SSW200FM	200 Gallons	SSW400FM	400 Gallons	Includes 24"H Stand*, Level Gauge, Lockable Fill Cap with Vent, Tank Mounted Gun Holder, and Fluidall Exclusive Non-Preset Pump Package (Fluidall Exclusive 3:1 T312 Oil Pump, 50' Industrial Grade Hose Reel, M3 Non-Preset Meter, Air Pressure Regulator, and Down Tube).
SSW315FM	315 Gallons	SSW280FM	280 Gallons	
Samson Dispense Package, Premium Preset Meter				
SSW200SP	200 Gallons	SSW400SP	400 Gallons	Includes 24"H Stand*, Level Gauge, Lockable Fill Cap with Vent, Tank Mounted Gun Holder, and Samson Preset Pump Package (Samson 3:1 PumpMaster Oil Pump, Samson 50' Reel, Samson Preset Meter, Air Pressure Regulator, and Down Tube).
SSW315SP	315 Gallons	SSW280SP	280 Gallons	
Samson Dispense Package, Premium Manual (Non-Preset) Meter				
SSW200SM	200 Gallons	SSW400SM	400 Gallons	Includes 24"H Stand*, Level Gauge, Lockable Fill Cap with Vent, Tank Mounted Gun Holder, and Samson Non-Preset Pump Package (Samson 3:1 PumpMaster Oil Pump, Samson 50' Reel, Samson Non-Preset Meter, Air Pressure Regulator, and Down Tube).
SSW315SM	315 Gallons	SSW280SM	280 Gallons	
Graco Dispense Package, Premium Preset Meter				
SSW200GP	200 Gallons	SSW400GP	400 Gallons	Includes 24"H Stand*, Level Gauge, Lockable Fill Cap with Vent, Tank Mounted Gun Holder, and Graco Preset Pump Package (Graco LD 3:1 Pump, Graco SDX 50' Reel, Graco Preset Gun, Air Pressure Regulator, Down Tube).
SSW315GP	315 Gallons	SSW280GP	280 Gallons	
Graco Dispense Package, Premium Manual (Non-Preset) Meter				
SSW200GM	200 Gallons	SSW400GM	400 Gallons	Includes 24"H Stand*, Level Gauge, Lockable Fill Cap with Vent, Tank Mounted Gun Holder, and Graco Non-Preset Pump Package (Graco LD 3:1 Pump, Graco SDX 50' Reel, Graco Non-Preset Gun, Air Pressure Regulator, Down Tube).
SSW315GM	315 Gallons	SSW280GM	280 Gallons	

Note: The 280 Gallon Steel Tank Packages DO NOT Include a 24"H Stand.

Mobile Single Wall Steel Tanks

Mobile Single Wall Steel Tanks							
Includes a Fully Welded Steel Ergonomic Handle, Built-In Bracket for Gun Holder/Placard Insert, Tank Mounted Reel Bracket and (4) 2" Top NPT Tank Openings.							
	SSWP60-3	(3) 60 Gallon Tanks Forklift Ready Includes 8" Casters.	46"L x 37"W x 46"H		SSWP110-2	(2) 110 Gallon Tanks Forklift Ready Includes 8" Casters.	53"L x 37"W x 46"H
	SSWP60-4	(4) 60 Gallon Tanks With Fork Pockets Only. Casters NOT Available.	49"L x 41"W x 36"H		SSWP125	(1) 125 Gallon Tank Includes 8" Casters.	48"L x 30"W x 45"H
	SSWP75	(1) 75 Gallon Tank Includes 8" Casters.	32"L x 27"W x 45"H		SSWP185	(1) 185 Gallon Tank Forklift Ready. Includes 8" Casters.	45"L x 37"W x 45"H
	SSWP75-2	(2) 75 Gallon Tanks Includes 8" Casters.	56"L x 30"W x 45"H	Fluid Level Gauge			
					SSWLG30	Use with SSWP60-3, SSWP60-4, SSWP75, SSWP75-2, SSWP110-2, SSWP125, & SSWP185	

ARMORCOAT

ArmorCoat Delivers Powerful Defense For Your Steel Tanks

This ultratough seamless polyurea barrier is applied directly to Fluidall's steel tanks during manufacturing. ArmorCoat is an exterior tank surface layer, built to protect and perform with properties that resist impact, abrasions, and corrosive chemicals, and even performs in extreme weather conditions. While ArmorCoat is a premium upgrade, this durable, monolithic steel tank armor is a smart investment delivering years of reliable protection, to ensure your steel tanks stay strong, durable, and built to last.



ArmorCoat Surface



Mobile Single Wall Steel Tank Packages



SSWP60-4GP Shown with Graco Preset Dispense Package



SSWP75-2GM Shown with Graco Preset Dispense Package



SSWP110-2GM Shown with Graco Non-Preset Dispense Package



SSWP75FP Shown with Fluidall Exclusive Dispense Package

Fluidall Exclusive Dispense Pkg, Premium Preset Meter

SSWP60-4FP	(4) 60 Gallon Tanks	Each Fluid Storage Tank Includes a Level Gauge, Lockable Fill Cap with Vent, Tank Mounted Gun Holder, and Fluidall Exclusive Preset Pump Package (Fluidall Exclusive 3:1 T312 Oil Pump, 50' Industrial Grade Hose Reel, M3 Preset Meter, Air Pressure Regulator, and Down Tube).
SSWP185FP	(1) 185 Gallon Tank	
SSWP125FP	(1) 125 Gallon Tank	
SSWP75FP	(1) 75 Gallon Tank	
SSWP75-2FP	(2) 75 Gallon Tanks	
SSWP60-3FP	(3) 60 Gallon Tanks	
SSWP110-2FP	(2) 110 Gallon Tanks	

Fluidall Exclusive Dispense Pkg, Premium Manual (Non-Preset) Meter

SSWP60-4FM	(4) 60 Gallon Tanks	Each Fluid Storage Tank Includes a Level Gauge, Lockable Fill Cap with Vent, Tank Mounted Gun Holder, and Fluidall Exclusive Non-Preset Pump Package (Fluidall Exclusive 3:1 T312 Oil Pump, 50' Industrial Grade Hose Reel, M3 Non-Preset Meter, Air Pressure Regulator, and Down Tube).
SSWP185FM	(1) 185 Gallon Tank	
SSWP125FM	(1) 125 Gallon Tank	
SSWP75FM	(1) 75 Gallon Tank	
SSWP75-2FM	(2) 75 Gallon Tanks	
SSWP60-3FM	(3) 60 Gallon Tanks	
SSWP110-2FM	(2) 110 Gallon Tanks	

Samson Dispense Package, Premium Preset Meter

SSWP60-4SP	(4) 60 Gallon Tanks	Each Fluid Storage Tank Includes a Level Gauge, Lockable Fill Cap with Vent, Tank Mounted Gun Holder, and Samson Preset Pump Package (Samson 3:1 PumpMaster Oil Pump, Samson 50' Reel, Samson Preset Meter, Air Pressure Regulator, and Down Tube).
SSWP185SP	(1) 185 Gallon Tank	
SSWP125SP	(1) 125 Gallon Tank	
SSWP75SP	(1) 75 Gallon Tank	
SSWP75-2SP	(2) 75 Gallon Tanks	
SSWP60-3SP	(3) 60 Gallon Tanks	
SSWP110-2SP	(2) 110 Gallon Tanks	

Samson Dispense Pkg, Premium Manual (Non-Preset) Meter

SSWP60-4SM	(4) 60 Gallon Tanks	Each Fluid Storage Tank Includes a Level Gauge, Lockable Fill Cap with Vent, Tank Mounted Gun Holder, and Samson Non-Preset Pump Package (Samson 3:1 PumpMaster Oil Pump, Samson 50' Reel, Samson Non-Preset Meter, Air Pressure Regulator, and Down Tube).
SSWP185SM	(1) 185 Gallon Tank	
SSWP125SM	(1) 125 Gallon Tank	
SSWP75SM	(1) 75 Gallon Tank	
SSWP75-2SM	(2) 75 Gallon Tanks	
SSWP60-3SM	(3) 60 Gallon Tanks	
SSWP110-2SM	(2) 110 Gallon Tanks	

Graco Dispense Package, Premium Preset Meter

SSWP60-4GP	(4) 60 Gallon Tanks	Each Fluid Storage Tank Includes a Level Gauge, Lockable Fill Cap with Vent, Tank Mounted Gun Holder, and Graco Preset Pump Package (Graco LD 3:1 Pump, Graco SDX 50' Reel, Graco Preset Gun, Air Pressure Regulator, Down Tube).
SSWP185GP	(1) 185 Gallon Tank	
SSWP125GP	(1) 125 Gallon Tank	
SSWP75GP	(1) 75 Gallon Tank	
SSWP75-2GP	(2) 75 Gallon Tanks	
SSWP60-3GP	(3) 60 Gallon Tanks	
SSWP110-2GP	(2) 110 Gallon Tanks	

Graco Dispense Pkg, Premium Manual (Non-Preset) Meter

SSWP60-4GM	(4) 60 Gallon Tanks	Each Fluid Storage Tank Includes a Level Gauge, Lockable Fill Cap with Vent, Tank Mounted Gun Holder, and Graco Non-Preset Pump Package (Graco LD 3:1 Pump, Graco SDX 50' Reel, Graco Non-Preset Gun, Air Pressure Regulator, Down Tube).
SSWP185GM	(1) 185 Gallon Tank	
SSWP125GM	(1) 125 Gallon Tank	
SSWP75GM	(1) 75 Gallon Tank	
SSWP75-2GM	(2) 75 Gallon Tanks	
SSWP60-3GM	(3) 60 Gallon Tanks	
SSWP110-2GM	(2) 110 Gallon Tanks	

Steel Lube Tanks, UL-142 Certified

Double and Single Wall Lube Tanks

Features a Universal Hose Reel Mount Plate



Steel Lube Single Wall Tanks					
SSW280PDLT	(5) 2" Top NPT, (1) 4" Emergency Vent	249 Gallons	12 Gauge	32"W x 30"L x 60"H	270 Lbs.
SSW275PDLT	(6) 2" Top NPT, (1) 4" Emergency Vent	308 Gallons	12 Gauge	27"W x 60"L x 44"H	320 Lbs.
SSW330PDLT	(6) 2" Top NPT, (1) 4" Emergency Vent	370 Gallons	12 Gauge	27"W x 72"L x 44"H	390 Lbs.
SSW500PDLT	(5) 2" Top NPT, (1) 4" Emergency Vent	498 Gallons	12 Gauge	32"W x 60"L x 60"H	447 Lbs.
SSW1000PDLT	(5) 2" Top NPT, (1) 6" Emergency Vent	997 Gallons	10 Gauge	32"W x 120"L x 60"H	929 Lbs.
Steel Lube Double Wall Tanks					
SDW280PDLTDW	(6) 2" Top NPT, (2) 4" Emergency Vent	249 Gallons	12 Gauge	32"W x 30"L x 60"H	513 Lbs.
SSW275PDLTDW	(6) 2" Top NPT, (2) 4" Emergency Vent	308 Gallons	12 Gauge	27"W x 60"L x 44"H	560 Lbs.
SSW330PDLTDW	(6) 2" Top NPT, (2) 4" Emergency Vent	370 Gallons	12 Gauge	27"W x 72"L x 44"H	700 Lbs.
SDW500PDLTDW	(5) 2" Top NPT, (2) 4" Emergency Vent	498 Gallons	12 Gauge	32"W x 60"L x 60"H	851 Lbs.
SDW1000PDLTDW	(6) 2" Top NPT, (2) 6" Emergency Vent	997 Gallons	10 Gauge	32"W x 120"L x 60"H	1,765 Lbs.

Double Walled Steel Waste Oil Tanks

UL-142 Certified and Features a Lockable Fill Box



Double Walled Steel Waste Oil Tanks				
Includes a 12" x 12" Lockable Fill Box, At-A-Glance Fluid Level Gauge, Interstitial Dip Stick, Downtube with 2" Camlock and Dust Cap.				
SDFTDW200	200 Gallons	2" Updraft Vent 3" Emergency Vent in Outer Tank 3" Emergency Vent in Inner Tank	36" x 36" x 40"H	576 Lbs.
SDFTDW500	500 Gallons	2" Updraft Vent 4" Emergency Vent in Outer Tank 4" Emergency Vent in Inner Tank	55" x 60" x 40"H	1070 Lbs.

Steel Waste Oil Tanks are Standard in Blue Acrylic Enamel Paint. Tanks are also offered in additional colors with a paint upcharge on each tank. (Black, White, Battleship Gray, Aluminum, Biloxi Tan, International Red, Orange, Yellow, JD Green).

Slim Steel Tanks UL-142 Certified

Slim Tanks Can Fit Through Doorways, into Pits and Bays and Along Aisle Ways. Built, Tested, & Labeled per UL-142.



Slim Single Wall Tanks				
Includes MNPT Emergency Vent, 2" MNPT Fill Cap, 2" Updraft Vent, 2" x 6" Nipple TBE, At-A-Glance Gauge.				
SSWSST120	120 Gallons		30"L x 29"W x 33"H	210 Lbs.
SSWSST180	180 Gallons	(6) 2" Top NPT, (2) 3" Top Ports	60"L x 29"W x 25"H	323 Lbs.
SSWSST200	200 Gallons		60"L x 29"W x 28"H	350 Lbs.
SSWSST280	280 Gallons		60"L x 27"W x 43"H	400 Lbs.
SSWSST350	350 Gallons	(6) 2" Top NPT, (2) 4" Top Ports	60"L x 29"W x 48"H	450 Lbs.
SSWSST500	500 Gallons		60"L x 33"W x 60"H	561 Lbs.
SSWSST750	750 Gallons	(6) 2" Top NPT, (2) 6" Top Ports	90"L x 41"W x 60"H	975 Lbs.
SSWSST1000	1,000 Gallons		96"L x 41"W x 60"H	1,236 Lbs.

Slim Double Wall Tanks				
Includes (2) MNPT Emergency Vents, 2" MNPT Fill Cap, 2" Updraft Vent, 2" x 6" Nipple TBE, At-A-Glance Gauge.				
SDWSST120	120 Gallons		36"L x 29"W x 33"H	359 Lbs.
SDWSST180	180 Gallons	(6) 2" Top NPT, (2) 3" Top Ports	66"L x 29"W x 25"H	580 Lbs.
SDWSST200	200 Gallons		66"L x 29"W x 28"H	673 Lbs.
SDWSST280	280 Gallons		67"L x 27"W x 43"H	814 Lbs.
SDWSST350	350 Gallons	(6) 2" Top NPT, (2) 4" Top Ports	67"L x 29"W x 48"H	955 Lbs.
SDWSST500	500 Gallons		67"L x 33"W x 60"H	1190 Lbs.
SDWSST750	750 Gallons	(6) 2" Top NPT, (2) 6" Top Ports	99"L x 41"W x 60"H	1610 Lbs.
SDWSST1000	1,000 Gallons		105"L x 41"W x 60"H	1835 Lbs.

Slim Steel Tanks & Bulk Steel Tanks are Standard in Blue Acrylic Enamel Paint.

Tanks are also offered in additional colors with a paint upcharge on each tank.
(Black, White, Battleship Gray, Aluminum, Biloxi Tan, International Red, Orange, Yellow, JD Green).
Tanks are Available with an Optional Hose Reel Bracket, Part No. SDWWRB.

Bulk Steel Tanks UL-142 Certified

Features a Fork Lift Skid Channel, & Formed Edge Welded Seams.



Bulk Single Wall Tanks				
Includes (1) MNPT Emergency Vent, 2" MNPT Fill Cap, 2" Updraft Vent, 2" x 6" Nipple TBE, At-A-Glance Gauge.				
SSWBT180	180 Gallons	(5) 2" Top NPT, (1) 4" Top Ports	36"L x 31"W x 40"H	315 Lbs.
SSWBT220	220 Gallons		36"L x 36"W x 40"H	400 Lbs.
SSWBT300	300 Gallons	(6) 2" Top NPT, (2) 4" Top Ports	36"L x 36"W x 55"H	446 Lbs.
SSWBT500	500 Gallons		41"L x 48"W x 60"H	625 Lbs.
SSWBT750	750 Gallons	(6) 2" Top NPT, (2) 6" Top Ports	54"L x 55"W x 60"H	1,025 Lbs.
SSWBT1000	1,000 Gallons		72"L x 55"W x 60"H	1,450 Lbs.

Bulk Double Wall Tanks				
Includes (2) MNPT Emergency Vents, 2" MNPT Fill Cap, 2" Updraft Vent, 2" x 6" Nipple TBE, At-A-Glance Gauge, & Leak Gauge.				
SDWBT180	180 Gallons	(6) 2" Top NPT, (2) 3" Top Ports	36"L x 36"W x 40"H	515 Lbs.
SDWBT300	300 Gallons	(6) 2" Top NPT, (2) 4" Top Ports	42"L x 36"W x 55"H	670 Lbs.
SDWBT500	500 Gallons		48"L x 48"W x 60"H	1,200 Lbs.
SDWBT750	750 Gallons	(6) 2" Top NPT, (2) 6" Top Ports	63"L x 55"W x 60"H	1,479 Lbs.
SDWBT1000	1,000 Gallons		81"L x 55"W x 60"H	1,754 Lbs.

Steel Bench Top Tanks, UL-142 Certified

Desirable in Service Shops, Pits & Bays. Doubles as a Handy Workspace



Steel Bench Top Tanks are Standard in Blue Acrylic Enamel Paint and Feature a Universal Hose Reel Mounting Plate.

Bench Single Wall Tanks			
12 Gauge Tank Includes (4) 2" Top NPT, (1) 4" Emergency Vent, and (1) 2" Bottom Drain			
SSW165PDWB	169 Gallons	33"W x 36"L x 33"H	170 Lbs.
SSW250PDWB	250 Gallons	32"W x 60"L x 30"H	293 Lbs.
SSW280PDWB	283 Gallons	33"W x 60"L x 33"H	305 Lbs.
SSW350PDWB	340 Gallons	33"W x 72"L x 33"H	350 Lbs.
SSW500PDWB	509 Gallons	33"W x 108"L x 33"H	560 Lbs.
Bench Double Wall Tanks			
12 Gauge Tank Includes (4) 2" Top NPT, (2) 4" Emergency Vents, and (1) 2" Bottom Drain			
SDW165PDWB	169 Gallons	33"W x 36"L x 33"H	388 Lbs.
SDW250PDWB	250 Gallons	32"W x 60"L x 30"H	580 Lbs.
SDW280PDWB	283 Gallons	33"W x 60"L x 33"H	596 Lbs.
SDW350PDWB	340 Gallons	33"W x 72"L x 33"H	677 Lbs.
SDW500PDWB	509 Gallons	33"W x 108"L x 33"H	1,000 Lbs.

Bench Top Steel Tanks UL-142 Certified









Bench Top Single Wall Tanks				
Includes MNPT Emergency Vent, 2" MNPT Fill Cap, 2" Updraft Vent, 2" x 6" Nipple TBE, and At-A-Glance Gauge.				
SSWBTT180	180 Gallons	(6) 2" Top NPT, (2) 3" Top Ports	39"L x 34"W x 33"H	400 Lbs.
SSWBTT280	280 Gallons	(6) 2" Top NPT, (2) 4" Top Ports	60"L x 34"W x 33"H	500 Lbs.
SSWBTT350	350 Gallons		60"L x 42"W x 33"H	550 Lbs.
SSWBTT500	500 Gallons		86"L x 42"W x 33"H	750 Lbs.
Bench Top Double Wall Tanks				
Includes (2) MNPT Emergency Vents, 2" MNPT Fill Cap, 2" Updraft Vent, 2" x 6" Nipple TBE, Leak Gauge, and At-A-Glance Gauge.				
SDWBTT180	180 Gallons	(6) 2" Top NPT, (2) 3" Top Ports	45"L x 34"W x 33"H	500 Lbs.
SDWBTT280	280 Gallons	(6) 2" Top NPT, (2) 4" Top Ports	67"L x 34"W x 33"H	675 Lbs.
SDWBTT350	350 Gallons		67"L x 42"W x 33"H	850 Lbs.
SDWBTT500	500 Gallons		93"L x 42"W x 33"H	1,050 Lbs.

Bench Top Steel Tanks are Standard in Blue Acrylic Enamel Paint.

Tanks are also offered in additional colors with a paint upcharge on each tank.
(Black, White, Battleship Gray, Aluminum, Biloxi Tan, International Red, Orange, Yellow, JD Green).
Tanks are Available with an Optional Hose Reel Bracket, Part No. SDWWRB.

Round/Obround-Horizontal/Vertical Tanks & Skids

Double or Single Walled Tanks Feature a Universal Hose Reel Mount Plate

Round Horizontal Single Wall Tanks		SSW150PDH	147 Gallons 12 GA Steel	(4) 2" Top NPT, (1) 4" NPT EMG Vent, (1) 2" Bottom Drain	30"Dia x 48"L
		SSW280PDH	264 Gallons 12 GA Steel	(4) 2" Top NPT, (1) 4" NPT EMG Vent, (1) 2" Bottom Drain	36"Dia x 60"L
		SSW500PDH	509 Gallons 10 GA Steel	(4) 2" Top NPT, (1) 4" NPT EMG Vent, (1) 2" Bottom Drain	48"Dia x 65"L
		SSW1000PDH	1,018 Gallons 10 GA Steel	(6) 2" Top NPT, (1) 6" NPT EMG Vent, (1) 2" Bottom Drain	48"Dia x 130"L
		SSW2000PDH	2,005 Gallons 7 GA Steel	(5) 2" Top NPT, (1) 6" NPT EMG Vent, (1) 2" Bottom Drain	64"Dia x 144"L
Round Horizontal Double Wall Tanks		SDW150PDHDW	147 Gallons 12 GA Steel	(4) 2" Top NPT, (2) 4" NPT EMG Vent, (1) 2" Monitoring Pipe	30"Dia x 48"L
		SDW280PDHDW	264 Gallons 12 GA Steel	(4) 2" Top NPT, (2) 4" NPT EMG Vent, (1) 2" Monitoring Pipe	36"Dia x 60"L
		SDW500PDHDW	509 Gallons 12 GA Steel	(5) 2" Top NPT, (2) 4" NPT EMG Vent, (1) 2" Monitoring Pipe	48"Dia x 65"L
		SDW1000PDHDW	1,018 Gallons 10 GA Steel	(5) 2" Top NPT, (1) 4" Top NPT, (2) 6" NPT EMG Vent, (1) 2" Monitoring Pipe	48"Dia x 130"L
		SDW2000PDHDW	2,005 Gallons 7 GA Steel	(5) 2" Top NPT, (1) 4" Top NPT, (2) 6" NPT EMG Vent, (1) 2" Monitoring Pipe	64"Dia x 144"L
Round Horizontal Single Wall Skids		SSW280PDSK	264 Gallons 12 GA Steel	(4) 2" Top NPT, (1) 4" NPT EMG Vent, (1) 2" Bottom Drain	36"Dia x 60"L
		SSW500PDSK	509 Gallons 10 GA Steel	(4) 2" Top NPT, (1) 4" NPT EMG Vent, (1) 2" Bottom Drain	48"Dia x 65"L
		SSW1000PDSK	1,018 Gallons 10 GA Steel	(6) 2" Top NPT, (1) 6" NPT EMG Vent, (1) 2" Bottom Drain	48"Dia x 130"L
		SSW2000PDSK	2,005 Gallons 7 GA Steel	(5) 2" Top NPT, (1) 6" NPT EMG Vent, (1) 2" Bottom Drain	64"Dia x 144"L
Round Horizontal Double Wall Skids		SDW280PDSKDW	264 Gallons 12 GA Steel	(4) 2" Top NPT, (2) 4" NPT EMG Vent, (1) 2" Monitoring Pipe	36"Dia x 60"L
		SDW500PDSKDW	509 Gallons 12 GA Steel	(5) 2" Top NPT, (2) 4" NPT EMG Vent, (1) 2" Monitoring Pipe	48"Dia x 65"L
		SDW1000PDSKDW	1,018 Gallons 10 GA Steel	(5) 2" Top NPT, (1) 4" Top NPT, (2) 6" NPT EMG Vent, (1) 2" Monitoring Pipe	48"Dia x 130"L
		SDW2000PDSKDW	2,005 Gallons 7 GA Steel	(5) 2" Top NPT, (1) 4" Top NPT, (2) 6" NPT EMG Vent, (1) 2" Monitoring Pipe	64"Dia x 144"L
Obround Horizontal Single Wall Tanks		SSW275PDOB	275 Gallons 12 GA Steel	(4) 2" Top NPT, (1) 4" NPT EMG Vent, (1) 2" Bottom Drain	27"W x 60"L x 44"H
		SSW330PDOB	330 Gallons 12 GA Steel	(4) 2" Top NPT, (1) 4" NPT EMG Vent, (1) 2" Bottom Drain	27"W x 72"L x 44"H
Obround Vertical Single Wall Tanks		SSW275PDV	275 Gallons 12 GA Steel	(4) 2" Top NPT, (1) 4" NPT EMG Vent, (1) 2" Bottom Drain	44"W x 27"Dia x 60"H
SSW330PDV		330 Gallons 12 GA Steel	(4) 2" Top NPT, (1) 4" NPT EMG Vent, (1) 2" Bottom Drain	44"W x 27"Dia x 72"H	
Obround Vertical Double Wall Tanks		SDW275PDVDW	275 Gallons 12 GA Steel	(4) 2" Top NPT, (2) 4" NPT EMG Vent, (1) 2" Interstitial Opening	44"W x 27"Dia x 60"H
		SDW330PDVDW	330 Gallons 12 GA Steel	(4) 2" Top NPT, (2) 4" NPT EMG Vent, (1) 2" Interstitial Opening	44"W x 27"Dia x 72"H
Round Vertical Single Wall Tanks		SSW500PDV	509 Gallons 12 GA Steel	(5) 2" Top NPT, (1) 4" NPT EMG Vent, (1) 2" Bottom Drain	48"Dia x 65"H
SSW1000PDV		1,002 Gallons 7 GA Steel	(5) 2" Top NPT, (1) 6" NPT EMG Vent, (1) 2" Bottom Drain	64"Dia x 72"H	
Round Vertical Double Wall Tanks		SDW500PDVDW	509 Gallons 12 GA Steel	(5) 2" Top NPT, (2) 4" NPT EMG Vent, (1) 2" Interstitial Opening	48"Dia x 65"H
		SDW1000PDVDW	1,002 Gallons 7 GA Steel	(5) 2" Top NPT, (2) 6" NPT EMG Vent, (1) 2" Interstitial Opening	64"Dia x 72"H

UL 2085 Aboveground Fireguard Tanks

Double Wall Cylindrical Fireguard Tanks are UL 2085 Listed, Feature UL Approved Saddles & are Painted with a White Urethane Top Coat

Fireguard Tanks; The Only Tank That Meets All Of These Standards:

- UL 2085 Listed "Protected" Tank
- Impact and Ballistics Protection per UL 2085
- Both the inner and outer steel tanks are built to UL standards
- National Fire Protection Association (NFPA) 30 & 30A
- International Fire Code (IFC)
- California Air Resources Board (CARB) Standing Loss Control testing requirements for air emissions
- Steel Tank Institute (STI) Standard F941 for Thermally Insulated Aboveground Storage Tanks



Standard UL 2085 Cylindrical Fireguard Tanks









Part No.	Capacity	Dimensions	Empty Weight
SDW500PDFG	500 Gallons	54" Dia x 70" L	Appx 2,500 Lbs.
SDW1000PDFG	1000 Gallons	54" Dia x 136" L	Appx 5,500 Lbs.
SDW2000PDFG	2000 Gallons	64" Dia x 144" L	Appx 10,000 Lbs.

Fireguard Tank Features:

- Capacities up to 15,000 gallons, with fast production for the 500, 1,000 and 2,000 gallon Fireguard Tanks. Request an estimate for other tank capacities.
- Compatibility: Primary storage tank and secondary containment are compatible with a wide range of fuels and chemicals, including biodiesel and ethanol.
- Insulation: The Fireguard lightweight monolithic thermal insulation material is a specialized concrete that is part of a patented process resulting in a lighter material weight than concrete alone. Stored fluid is insulated from ambient temperature variations, resulting in reduced vapor emissions and product loss.
- Tank Testing: Primary and secondary tanks can be tightness tested on-site with standard procedures, and the interstitial space can be monitored for inner tank leak detection.
- Double Wall Tank: An impermeable, crack resistant steel outer tank encloses the concrete encased inner primary tank. The steel outer wall provides added strength and protection from weathering, low cost maintenance and is easily recycled.

Cylindrical Tanks

Part No.	Gallon Capacity	DIA	Height	Top Opening	Outlet Size	Part No.	Gallon Capacity	DIA	Height	Top Opening	Outlet Size
44844	10	12"	26"	8"	3/4"	40606	750	48"	103"	16"	2"
44846	20	16"	28"	8"	3/4"	42214	850	48"	118"	16"	2"
41867	25	18"	29"	5"	3/4"	40152	1,000	64"	80"	16"	2"
44848	40	18"	42"	8"	3/4"	40070	1,100	87"	53"	16"	2"
41865	50	18"	53"	5"	3/4"	40144	1,500	64"	116"	16"	2"
45192	65	23"	43"	8"	1 1/4"	40010	1,700	87"	74"	16"	2"
41863	75	23"	49"	8"	1 1/4"	47109	2,000	64"	152"	16"	2"
41861	100	28"	43"	8"	1 1/4"	40178	2,100	87"	89"	16"	2"
40803	105	23"	63"	8"	2"	40051	2,500	95"	91"	16"	2"
44102	130	32"	46"	8"	1 1/4"	40754	3,000	95"	109"	16"	2"
41859	150	30"	56"	8"	1 1/4"	41403	4,200	102"	131"	16"	3"/2"
44536	160	28"	69"	8"	2"	40164	5,000	102"	152"	22"	3"/2"
C205	205	32"	63"	(2) 2"	1"	40226	6,000	102"	182"	16"	3"/2"
47401	210	32"	67"	16"	2"	40224	6,500	119"	150"	16"	3"/2"
40320	220	42"	44"	5"	1 1/4"	40663	7,800	119"	176"	16"	3"/2"
44538	225	31"	77"	8"	2"	44395	8,400	120"	187"	16"	3"/2"
41854	250	30"	89"	8"	2"	43128	10,000	141"	160"	22"	3"/2"
45875	265	31"	91"	8"	2"	44015	13,000	144"	198"	22"	3" 316 Stainless Steel Bolted Fitting
40213	300	35"	79"	16"	2"						
40148	500	48"	73"	16"	2"						
40023	550	67"	44"	16"	2"						

205 Gal Cylindrical System & Accessories			Portable Cylindrical Carts		
	C205-1	Gravity Feed System Includes: 205 Gallon Tank, 24"H Stand, 1-Pan Drip Tray Assembly and Gravity Feed Dispense Kit. 32"W x 42"D x 90"H		PTGC25	25 Gallon Cylindrical Tank on Steel Cart With 2" & 5" Fill Ports. Cart Dimensions: 24"W x 38"H Tank Dimensions: 18"OD x 29"H 45 lbs.
	C205	205 Gallon Cyl. Tank with (2) 2" Top and (1) 1" Bottom Outlet. Constructed from UL Rated Food-Grade Polyethylene Resins with Extra Strength Ribbed Side Walls 32"OD x 63"H			
	CS32	Steel Stand , 24"H x 32"OD			
	DTHC	Drip Tray Assy Includes Pan, Screen, Frame			
	DPTHC	Drip Tray Frame , Steel		FHGPC16	Cart Frame For 25 Gallon Barrel.
				FHGPC55	Cart Frame For 55 Gallon Barrel.

Work Bench Tanks

The Ultimate Solution for Efficiently Storing and Dispensing Automotive Fluids and Lubricants in Confined Shop Applications



Conveniently Enclose 2, 3, or 4 Tote-A-Lube Tanks Contained in a Secondary Containment Vessel.

The Work Bench is complete with a 69" x 36" powder coated work surface which will remain clean and free of oil residue, as the tanks' fill ports are located below the work area. It is equipped with a universal side shelf that mounts Graco's dispense equipment, giving you the ultimate in fluid storage solutions for confined spaces.

Dispense packages and custom configurations are available upon request.



15 Gallon Rack Tanks & Systems

Rack Tanks		Rack Tank Systems			
Manufactured from UL rated translucent food-grade polyethylene. Features a sloped bottom, 2" angled fill port, 3/4" polyethylene valve, (2) molded front inserts to secure handles (included) and placard kit (not included).			Tanks Feature a 3/4" Polyethylene Valve & Aluminum Handles. (Handles not shown in all photos. Placard Kit Not Included.)		
T15-1	14.4"W x 20"D x 18.75"H		T15-B1	Includes (1) 15 Gallon Tank & Power Coated Steel Base 14.4"W x 20"D x 18.75"H	
			T15-B2	Includes (2) 15 Gallon Tanks & Power Coated Steel Base 29"W x 20"D x 18.75"H	
			T15-B3	Includes (3) 15 Gallon Tanks & Power Coated Steel Base 44"W x 20"D x 18.75"H	
			T15-B4	Includes (4) 15 Gallon Tanks & Power Coated Steel Base 58"W x 20"D x 18.75"H	
Rack Tank Accessories			T15-CR4	Castored Rack Tank System with (4) Tanks with Valves & Aluminum Handles on Castored Powder Coated Steel Base with 2 Welded Shelves. Load capacity of 540 lbs. 33.5"W x 30"D x 66"H.	
	PLAC58		Placard Kit Includes Hardware	T15-CR8	Castored Rack Tank System with (8) Tanks with Valves & Aluminum Handles, on Castored Powder Coated Steel Base with 2 Welded Shelves. Load capacity of 540 lbs. 63"W x 30"D x 66"H.
	HANDLE6		Aluminum Handle Includes Hardware		





Jobber Packages for Oil

Cost-Effective Solutions to Maximize The Efficiency of Fluid Management and Allow for Bulk Fluid Delivery





Fluidall Exclusive Jobber Packages for Oil

	Tote-A-Lube Tank & Fluidall Exclusive Preset Dispense Package (3:1 T312 Oil Pump, Hose Reel with 50' Hose, M3 Preset Meter, Air Pressure Regulator) and Fully Welded Steel Cage with Placard. 44"W x 44"D Footprint.				Tote-A-Lube Tank & Fluidall Exclusive Preset Dispense Package (3:1 T312 Oil Pump, Hose Reel with 50' Hose, M3 Preset Meter, Air Pressure Regulator) and Steel Containment Vessel with Legs. 46"W x 46"D Footprint.		
	JT180SDPFE	180 Gallons	56"H		JT180DCVPE	180 Gallons	56"H
	JT240SDPFE	240 Gallons	66"H		JT240DCVPE	240 Gallons	66"H
	JT330SDPFE	330 Gallons	80"H		JT330DCVPE	330 Gallons	80"H

Samson Jobber Packages for Oil



 	Tote-A-Lube Tank & Samson Dispense Package (3:1 PumpMaster Oil Pump, Reel with 50' Hose, Preset Meter, Air Pressure Regulator) and Fully Welded Steel Cage with Placard. 44"W x 44"D Footprint.			 	Tote-A-Lube Tank & Samson Dispense Package (3:1 PumpMaster Oil Pump, Reel with 50' Hose, Preset Meter, Air Pressure Regulator) and Steel Containment Vessel with Legs. 46"W x 46"D Footprint.		
	JT180SDPS	180 Gallons	56"H		JT180DCVPS	180 Gallons	56"H
	JT240SDPS	240 Gallons	66"H		JT240DCVPS	240 Gallons	66"H
	JT330SDPS	330 Gallons	80"H		JT330DCVPS	330 Gallons	80"H

Graco Jobber Packages for Oil



 	Tote-A-Lube Tank & Graco Dispense Package (3:1 LD Series Pump, SD Series Reel with 50' Hose, LD Series LDP5 Preset Meter, Air Pressure Regulator) and Fully Welded Steel Cage with Placard. 44"W x 44"D Footprint.			 	Tote-A-Lube Tank & Graco Dispense Package (3:1 LD Series Pump, SD Series Reel with 50' Hose, LD Series LDP5 Preset Meter, Air Pressure Regulator) and Steel Containment Vessel with Legs. 46"W x 46"D Footprint.		
	JT180SDPG	180 Gallons	56"H		JT180DCVPG	180 Gallons	56"H
	JT240SDPG	240 Gallons	66"H		JT240DCVPG	240 Gallons	66"H
	JT330SDPG	330 Gallons	80"H		JT330DCVPG	330 Gallons	80"H

Jobber Packages for Coolant

Samson Jobber Packages for Coolant





 	Tote-A-Lube Tank and Samson Coolant Pump Package (1:1 Pump, Reel with 50' Hose, Non-Metered Control Handle, Air Regulator) and Fully Welded Steel Cage with Placard. 44"W x 44"D Footprint. Optional Containment Vessel Available.		
	JT180SCP	180 Gallons	56"H
	JT240SCP	240 Gallons	66"H
	JT330SCP	330 Gallons	80"H

Graco Jobber Packages for Coolant

 	Tote-A-Lube Tank and Graco Coolant Pump Package (Husky 716 DDP Pump, Reel with 50' Hose, Non-Metered Control Handle, Air Regulator) and Fully Welded Steel Cage with Placard. 44"W x 44"D Footprint. Optional Containment Vessel Available.		
	JT180GDCP	180 Gallons	56"H
	JT240GDCP	240 Gallons	66"H
	JT330GDCP	330 Gallons	80"H

Bulk Washer Fluid Systems & Dispensers

Ideal For Retail, Commercial Sites, & Fleet Stations

	Outdoor Washer Fluid Systems			Indoor Washer Fluid Systems		
	Features a UL Listed 110V Electric Pump (1.6gpm), Dispense Nozzle, 25' Coil Hose, and Weather Proof Pump Enclosure.			Features a UL Listed 110V Electric Pump (1.6gpm), Dispense Nozzle and a 25' Coil Hose.		
	WWQ160O	160 Gallons	28"Dia. x 69"H	WWQ160I	160 Gallons	28"Dia. x 69"H
	WWQ205O	205 Gallons	32"Dia. x 63"H	WWQ205I	205 Gallons	32"Dia. x 63"H
	WWQ300O	300 Gallons	35"Dia. x 79"H	WWQ300I	300 Gallons	35"Dia. x 79"H
WWQ500O	500 Gallons	48"Dia. x 73"H	WWQ500I	500 Gallons	48"Dia. x 73"H	
	Washer Fluid Dispensers and Accessories					
	WW-QWD-WMB-O	Outdoor Washer Fluid Dispenser Features a Weather Proof Pump Enclosure with a UL Listed 110V Pump (1.6gpm), Dispense Nozzle and 25' Coil Hose. Mount on/near tank (not included). 18"H x 10"W x 5"D		WW-QWD-LID	Washer Fluid Drum Lid Dispenser Includes an aluminum lid, drop tube, UL Listed 110V Electric Pump (1.6gpm), Dispense Nozzle and 25' Coil Hose. 24" Dia x 6"H	
	WW-QWD-WM-I	Indoor Washer Fluid Dispenser Features a UL Listed 110V Pump (1.6gpm), Dispense Nozzle and 25' Coil Hose. Mount on/near tank (not included). 18"H x 10"W x 5"D		WW-QWA-CH25	25' Coiled Replacement Hose Allows users to dispense washer fluid directly into vehicles.	

Waste Coolant Tanks

	Waste Coolant Tanks		
	Part No.	C160FTAWC	C300FTAWC
	Capacity	160 Gallons	300 Gallons
	Openings	Tank with 1"MNPT, 2" MNPT Fitting and 8" Lid	Tank with 1"MNPT, 2" MNPT Fitting and 16" Lid
	Dimensions	28"OD x 69"H	35"OD x 79"H
	Weight	55 Lbs.	79 Lbs.



GEMRIK DEF Shelter

The Climate-Controlled Diesel Exhaust Fluid Solution with a Fuel-Island Friendly Footprint



Construction

- Ships Fully Assembled for Efficient Installation
- CNC Cut Powder Coated Aluminium Shelter Assembled with Heavy Duty Stainless Steel Rivet System
- Dual Locking Gas Shock Assisted Side Doors with Three Position Click Hinges
- 4" Base with Side Forklift Access
- Interior Anchoring Hole Points
- 4 GFCI-15A Dual Duplex Interior Electrical Receptacles
- Manual Shut-Off to Interior Electrical Receptacle Box
- Single Phase, 115V Exterior Junction Box
- Heater With Thermostat
- Insulated Ceiling & Side Walls



Tote-Ready DEF Shelters

Part No.	Fully Insulated	Dispense Pkg.	Capacity	Dimensions (76.375"H)
DEFGR330	Insulated Sides and Ceiling. Heater and Thermostat Included.	Pump, Nozzle, Hose Reel and Meter Included.	1 Tote (NOT Included)	48"W x 76.75"D
DEFGR660			2 Totes (NOT Included)	48"W x 132"D
DEFGR990			3 Totes (NOT Included)	48"W x 187.5"D

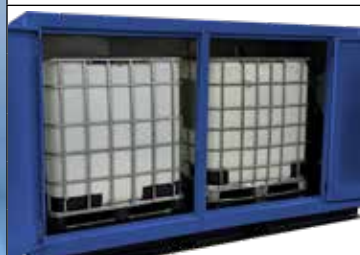

DEF Shelters with Inner IBCs Included

Part No.	Fully Insulated	Dispense Pkg.	Capacity	Dimensions (76.375"H)
DEFGR330TI	Insulated Sides and Ceiling. Heater and Thermostat Included.	Pump, Nozzle, Hose Reel and Meter Included.	330 Gallons	48"W x 76.75"D
DEFGR660TI			660 Gallons	48"W x 132"D
DEFGR990TI			990 Gallons	48"W x 187.5"D

Features

- Sealed Closed Loop Micro-Matic Dispense and Fill System
- Self-Priming Graco DEF Pump
- DEF Hose Reel with 33' Hose
- Graco Digital Dispense Meter
- Stainless Steel Automatic Shut-Off Dispense Nozzle
- All Fill & Dispense Components are Connected & Ready to Use
- Optional IBC Totes
- Optional Pulse Meter



Commercial Platinum Bulk DEF Systems



Commercial Platinum DEF Systems			
DEFKOM1000B1	1,000 Gallon Cap.	48"W x 132"L x 110"H	2,000 Lbs.
DEFKOM2000B1	2,000 Gallon Cap.	73"W x 197"L x 94"H	3,000 Lbs.
DEFKOM3400B1	3,400 Gallon Cap.	93"W x 192"L x 107"H	3,900 Lbs.
DEFKOM6000B1	6,000 Gallon Cap.	110"W x 231"L x 126"H	6,200 Lbs.

Dispense System (Required)	
DEFOPT-2DB1	20' Hose Assembly (Hose Reel, 20' Hose, Swivel/Breakaway & Mis-Fill Prevention Nozzle)
DEFOPT-R30B1	30' Hose Assembly (Hose Reel, 30' Hose, Swivel/Breakaway & Mis-Fill Prevention Nozzle)
DEFOPT-40B1	40' Hose Assembly (Hose Reel, 40' Hose, Swivel/Breakaway & Mis-Fill Prevention Nozzle)

Optional Equipment	
DEFOPT-HB1	Thermostatically Controlled Heater
DEFOPT-EB1	Exhaust Fan w/ Timer
DEFOPT-LB1	Low Level Warning Indicator Light
DEFOPT-LTAB1	Low Temperature Strobe Light
DEFOPT-GB1	GFCI Outlet in Control Room
DEFOPT-ZB1	Control Room Light
DEFOPT-FB1	DEF Product Filter (1 Micron Polyethylene)
DEFOPT-OB1	Stainless Steel Overfill Prevention Valve
DEFOPT-IB1	Interstitial Leak Detection
DEFOPT-TB1	Multi-Dispenser Setup for Remote Dispensers (Isotrol, Piping Tee, Pump Upgrade, Solenoid)
DEFOPT-AB1	Bolt-Down Anchoring Kit
DEFOPT-AHCB1	Hurricane Code Upgrade Anchoring Kit
DEFRLF-1000NB1	1,000 G Leveling Frame with Bold Down Anchor
DEFRLF-2000B1	2,000 G Leveling Frame with Bold Down Anchor

Features

- Pre-Wired Electrical Components
- 110% Sec. Containment
- Insulated FRP Panels
- Forklift Ready Base Frame
- Submersible 1/2 HP DEF Pump
- Audible Overfill Alarm
- Pulse Output, Card Reader Compatible
- Magnetic Mis-Fill Prevention Nozzle, Swivel-Breakaway & Spare Mag Collar
- Fluid Level Display
- 2" Fill-Port Dry Break Adapter



Shown with Optional 2nd Dispense Package

DEF Insulated Dispense Cabinet



DEF Insulated Dispense Cabinet	
DEFGRDC	Features an Interior Pump Mounting Plate, Power Source, and an Open Back for Multiple Installation Configurations. 26" x 26" x 64"H
Optional Cabinet Equipment	
DHG24V646	Metered Graco 12V Pump Package with Meter 9.5gpm, 20' Discharge Hose, 5' Suction Hose, LD Auto Nozzle, Meter
DHG24V641	Metered Graco 120V Pump Package with Meter 9gpm, 20' Discharge Hose, 5' Suction Hose, LD Auto Nozzle, Meter
DHG24V645	Non Metered Graco 120V Pump Package, Non-Metered 9gpm, 20' Discharge Hose, 5' Suction Hose, LD Auto Nozzle.
DEF33REEL	33' DEF Hose Reel 3/4" x 33' Hose
DEF550CH	550w Electric Heater

Bulk DEF All-In-One

Complete Bulk DEF Tank & Dispense Packages Arriving Fully Assembled



DEFECO2100
Shown with DEFECO33HRP

ECO DEF Packages

Large DEF Tank, 120V Pump, Digital Flow Meter, Auto Nozzle, 20' Delivery Hose.

DEFECO205	205 Gallons	32"Dia x 63"H Tank
DEFECO300	300 Gallons	35"Dia x 79"H Tank
DEFECO500	500 Gallons	48"Dia x 73"H Tank
DEFECO850	850 Gallons with Remote Fill	48"Dia x 118"H Tank
DEFECO1000	1,000 Gallons with Remote Fill	64"Dia x 80"H Tank
DEFECO1500	1,500 Gallons with Remote Fill	64"Dia x 116"H Tank
DEFECO2100	2,100 Gallons with Remote Fill	87"Dia. x 89"H Tank

Optional ECO DEF Equipment

DEFECO33HRP	33' Hose Reel Package for ECO DEF Includes 33' Hose Reel, Mounting Bracket, All Plumbing and Hardware. Installed on the ECO DEF Tank.	
--------------------	--	--

Northern DEF Packages (Heated & Insulated)

Bulk Insulated Polyethylene DEF Tank with Reinforced Tank Wrap, (1) 2" Bulkhead and (2) QD Valves. Inside the Lockable (Tank Mounted) Stainless Steel Cabinet is a ULC TD10 115V Diaphragm Pump, Turbine Flow Meter, 25' Hose Reel, 650W Heater w/ Auto Thermostat, Digital Fluid Level Indicator, 2" Camlock Fill, Stainless Steel Auto Nozzle, Audible Overfill Alarm (Sounds @85% Full) and Gun Holder. Requires 115V Circuit & 30 Amp Dedicated Breaker.

Cabinet Dimensions add additional 24"W x 25"D x 48"H.

DEFPRO500B1N	500 Gallons	52"Dia. x 75"H Tank
DEFPRO750B1N	750 Gallons	52"Dia. x 105"H Tank
DEFPRO850B1N	850 Gallons	52"Dia. x 120"H Tank
DEFPRO1000B1N	1,000 Gallons	68"Dia. x 82"H Tank
DEFPRO1050B1N	1,050 Gallons	52"Dia. x 136"H Tank
DEFPRO1500B1N	1,500 Gallons	68"Dia. x 118"H Tank
DEFPRO2000B1N	2,000 Gallons	68"Dia. x 154"H Tank
DEFPRO2100B1N	2,100 Gallons	91"Dia. x 91"H Tank
DEFPRO3000B1N	3,000 Gallons	99"Dia. x 111"H Tank

Optional Northern DEF Equipment

DEFPROHR50B1N	Optional 50' Hose Reel	
DEFPRO2FB1N	Optional 2" Fitting Top of Tank for Monitoring System	
DEFPROPMB1N	Optional Pulse Meter	
Please Inquire	Immersion Heater for Extreme Temperatures.	



Dispense Package
Shown Inside
Stainless Steel
Cabinet

Heated Double Wall DEF Cubes

Premium Heated Bulk DEF Solutions

DEF Cube Features:

- Outer Tank Holds 110% of Inner Tank Volume
- 6 GPM 120V Pump
- Integral Sump
- Electronic Overfill Sensor
- Optical Bund Alarm
- 2" Dry-Break Fill Port
- Liquid Level Gauge
- Auto Nozzle and Nozzle Holder
- Fully Assembled and Pre-Wired
- Optional Pulse Meter Allows User to Connect to Most Card Reader Systems.
- Electrical Requirements: (1) 120v, 30 amp



 660 Gallon Cube	DEF Cubes Include: Heater, TD10-120V Diaphragm Pump, Meter, 25' Hose Reel, Stainless Steel Auto Nozzle, and Lockable Hinged Lid.				
	DEF9050253B1	400 Gallon Heated Cube with Flow Meter	400W Heater	47"W x 45"L x 71"H	
	DEF9050257B1	400 Gallon Heated Cube with Pulse Meter			
	DEF90502510B1	400 Gallon Extreme Heated Cube with Flow Meter	400W Heater and Internal Heating Coil		
	DEF90502511B1	400 Gallon Extreme Heated Cube with Pulse Meter			
	DEF9050263B1	660 Gallon Heated Cube with Flow Meter	400W Heater		47"W x 71"L x 71"H
	DEF9050267B1	660 Gallon Heated Cube with Pulse Meter			
	DEF9050268B1	660 Gallon Extreme Heated Cube with Flow Meter	400W Heater and Internal Heating Coil		
	DEF90502611B1	660 Gallon Extreme Heated Cube with Pulse Meter			
	DEF9050280B1	1,320 Gallon Heated Cube with Pulse Meter	400W Heater		
DEF9050281B1	1,320 Gallon Heated Cube with Flow Meter				



Jobber Packages for DEF

Refillable Cost-Effective Packages That Allow for Bulk Fluid Delivery



12V Jobber Packages for DEF		
Features a Refillable Poly Tank, Fully Welded Steel Cage with Placard for ID Labels and Graco DEF Pump Package (12V Pump, Reel w/ 33' Hose, In-Line Meter, Auto Nozzle).		
DEFJT18012V646	180 Gallons	44"W x 44"D x 56"H
DEFJT24012V646	240 Gallons	44"W x 44"D x 66"H
DEFJT33012V646	330 Gallons	44"W x 44"D x 80"H
120V Jobber Packages for DEF		
Features a Refillable Poly Tank, Fully Welded Steel Cage with Placard for ID Labels and Graco DEF Pump Package (120V Pump, Reel w/ 33' Hose, In-Line Meter, Auto Nozzle).		
DEFJT180120V641	180 Gallons	44"W x 44"D x 56"H
DEFJT240120V641	240 Gallons	44"W x 44"D x 66"H
DEFJT330120V641	330 Gallons	44"W x 44"D x 80"H

Heated Tank Blankets

Provides Even Heat for Temperature Sensitive Applications



Once Fluid Reaches the Desired Set Temperature, the Insulated Heated Blankets Maintain Temperature, Even in the Most Challenging Applications.

Features

- Constructed of 18oz NFPA Certified Flame Retardant Vinyl (Also Water, Wear and UV Resistant)
- High Efficiency Carbon Heating Grid Evenly Distributes Heat
- Heating Element Decreases Current as Temperature Increases
- Integrated GFCI is Hard Wired into Blanket
- Adjustable Retaining Straps with Quick Release Buckles for an Accurate Fit
- Fully Welded Seam Seals all Vinyl Perimeters

Tote-A-Lube Tank Heated Blankets			
	HBFT180	Fits T180 Tank	136°F Max. Temp., 120 VAC, 1440 Watts, 12 Amps
	HBFT240	Fits T240 Tank	
	HBFT330	Fits T330 Tank	
IBC Tote Heated Blankets			
	HBFT275IBC	Fits 275 Gallon Tote	136°F Max. Temp., 120 VAC, 1440 Watts, 12 Amps
	HBFT330IBC	Fits 330 Gallon Tote	
IBC Tote Heated Blankets, Extended Frame			
	HBFT275IBCXL	Fits 275 Gallon Tote	Extended Frame Allows for Pump Housing, Controller and Insulated Cover. 136°F Max. Temp., 120 VAC, 1440 Watts, 12 Amps
	HBFT330IBCXL	Fits 330 Gallon Tote	
55 Gallon Drum Heated Blankets			
	HBFT55D	Fits 55 Gallon Drum	158°F Max. Temp., 120 VAC, 780 Watts, 7 Amps
Temperature Probe (Optional)			
	HBTB1	6' Probe utilizes programmable dual display temperature controls, user-resettable circuit breakers, and 5' power cord.	

High Volume DEF Transfer Equipment Designed to Transfer Intermediate Quantities of DEF

	High Flow DEF Transfer Carts		Optional Cart Equipment		High Flow DEF Transfer Skid (Custom Built) Transfer DEF in Large Quantities. Contact Fluidall for Customization Options & Pricing. 
	Includes TC10 Centrifugal Pump (Flooded Suction/Self Priming, Electric Start, 3/4 HP, 115V 10A, Continuous Duty with 35+gpm Open Flow Rate), 10' x 1 1/4" Suction Hose and 20' x 1" Dispense Hose.		DEFTCMMCAKB1	Micromatic Coupler Adapter Kit	
	DEFTCWMMB1	High Flow DEF Transfer Cart, WM Meter with Air Eliminator & Filter			
	DEFTCFMB1	High Flow DEF Transfer Cart, Flow Meter	DEFTCDNAKB1	Drumming Nozzle Adapter Kit	
	DEFTCNMB1	High Flow DEF Transfer Cart, No Meter	DEFTCPFB1	Poly Filter	









Portable DEF Transfer Packages

32 Gallon 12V HD DEF Truck Tank				
	DEF32TTD	Includes a Forklift Ready, Powder Coated Steel Cage, Bulkhead Draw Kit, Graco 12V DEF Dispense Package (9.5gpm Pump, Flow Meter, Auto-Shut Off Gun, & 33' Hose Reel).	32 Gallons	22"L x 51"W x 26"H
Poly DEF Dispense Units				
	DEF9040010B1	Equipped with TD10-12V Pump, 20' Dispense Hose, and Auto Nozzle with Swivel.	33 Gallons	32"L x 24"W x 18"H
	DEF9040020B1		53 Gallons	32"L x 24"W x 23"H
	DEF9040030B1		113 Gallons	46"L x 30"W x 29"H
	DEF9040040B1		158 Gallons	46"L x 32"W x 40"H
Portable Steel DEF Units, Not Heated				
	DEF9040202B1	Features a TD-12V Pump, 20' Dispense Hose and 4' Suction Hose with Detachable Steel Drum/Tote Bracket, Stainless Steel Auto Nozzle with Swivel & Integrated Nozzle Holder, and 4-Pin Closed System.	20 Gallons	30"W x 18"L x 22"H
	DEF9040602B1		60 Gallons	45"W x 24"L x 30"H
	DEF9041002B1		100 Gallons	48"W x 30"L x 34"H
Portable Steel DEF Dispense Unit, Heated				
	DEF9040604B1	Features are the same as the non-heated Steel DEF Units, with the addition of a 20 vac 475W Heating System.	60 Gallons	45"W x 24"L x 30"H
	DEF9041004B1		100 Gallons	48"W x 30"L x 34"H
Cylindrical Tank on Steel Cart				
	DEFPC25GHP	Includes Graco DEF Manual Hand Pump, 6' Hose & Manual Nozzle.	25 Gallons	Cart: 24"W x 38"H Tank: 18"OD x 29"H
DEF Cubetainers				
	1032101N95401	DEF Cubetainers Includes (2) Top Buttress Thread Connections with Plugs and (4) Stainless Steel Front Inserts for Pump Bracket.	80 Gallons	36.5" x 36.5" x 22"H
	1032201N95401		120 Gallons	36.5" x 36.5" x 31"H
	1032301N95401		180 Gallons	36.5" x 36.5" x 44"H
	1032401N95401		260 Gallons	36.5" x 36.5" x 57.5"H
	DEFSC180P	DEF Cubetainers with Bolted-On Pallet Base Includes Cubetainer Tank, Pallet Base and Attachment Hardware.	80 Gallons	36.5" x 36.5" x 28.5"H
	DEFSC120P		120 Gallons	36.5" x 36.5" x 37.5"H
	DEFSC180P		180 Gallons	36.5" x 36.5" x 50.5"H
	DEFSC260P		260 Gallons	36.5" x 36.5" x 64"H
DEF Cubetainer Accessories				
	SCTDEFT-PMPBR	DEF Pump Bracket For 120, 180 & 260 Gallon DEF Cubetainers		
	SCT80-DEFMMKIT	Micromatic RSV & Drawtube Assembly	For 80 Gallon Cubetainer	
	SCT120-DEFMMKIT		For 120 Gallon Cubetainer	
	SCT180-DEFMMKIT		For 180 Gallon Cubetainer	
	SCT260-DEFMMKIT		For 260 Gallon Cubetainer	





DEF Equipment

Graco DEF Pump Packages			DEF Meters	
	DHG24V646	Metered Graco 12V Pump Package 9.5gpm with 20' Discharge Hose, 5' Suction Hose LD Auto Nozzle with Stainless Steel Spout, LD DEF Meter.		DHG127663 Graco DEF LD In-Line Turbine Meter
	DHG24V641	Metered Graco 120V Pump Package 9gpm with 20' Discharge Hose, 5' Suction Hose LD Auto Nozzle with Stainless Steel Spout, LD DEF Meter.		DEFTNOXPM Turbinox - Turbine Pulse Meter
	DHG24V645	Non Metered Graco 120V Pump Pkg 9gpm with 20' Discharge Hose, 5' Suction Hose LD Auto Nozzle with Stainless Steel Spout. Non-Metered.		DEF Nozzles
	SMTS-DEF	DEF SMTS Package: 120v Graco DEF Pump, 33' DEF Reel, SS Auto Dispense Nozzle, SMTS Shelf, Hoses and Components. Use w/ Large Tote-A-Lube Tanks and Cubetainer Tanks (Excluding 60 Gal. Cubetainer).	DEF Components	
				DEFMMKIT1 Micro-Matic Closed System
	DEF Hand Pumps			
	DEFGHP	Graco LD Series DEF Hand Pump 11oz/Stroke. Includes Integrated 2" Bung Adapter and Adjustable Telescoping Down-Tube		NPT2B Buttress 2" FNPT to 2" MNPT
	FF51505-D	Hand Operated 3 Vane Rotary Hand Pump for DEF, 8GPM. Fits 55 Gallon Drum. Includes Pump Housing, Handle, 5' Hose, Relief Spring, Tether with Plug and Static Line, 3 Draw Tubes, and Bung Adaptor.		DEFRSVT39 RSV Down Tube 39"
	DEF Hose Reel & Hose			
	DEF33REEL	Hose Reel 3/4" x 33' Hose		DEFRSVT59 RSV Down Tube 59"
	34DEFFT	Hose, Black, 3/4"ID Per Foot		DEF911-009-0 High-Flow DEF Dispense Coupler
	Remote DEF Dispense Pedestals			
	DEF90202814B1	Remote Pedestal, TD10-120V Diaphragm Pump, Flow Meter, 20' Dispense Hose, 6' Suction Hose, & Auto Nozzle. 15"W x 15"D x 54"H		DEFRSVFC RSV Fill Coupler
	DEF90202818B1	Remote Pedestal, TD10-120V Diaphragm Pump, Pulse Meter, 20' Dispense Hose, 6' Suction Hose, & Auto Nozzle. 15"W x 15"D x 54"H		DEFRSVDCB RSV Dispense Valve w/ Barbed Fitting
	DEF90202822B1	Remote Pedestal, TD10-120V Diaphragm Pump, Flow Meter, 25' Hose Reel, & Auto Nozzle. 26 1/4"W x 15"D x 54"H		DEFRSVV RSV Stainless Valve Buttress Thread
	DEF90202823B1	Remote Pedestal, TD10-120V Diaphragm Pump, Pulse Meter, 25' Hose Reel, & Auto Nozzle. 26 1/4"W x 15"D x 54"H		DEFRSVVBSP RSV Stainless Valve BSP (Fine) Thread
			DEFVB Vent 2 Way Vacuum Style	

FLO-FAST for DEF (Diesel Exhaust Fluid)



















	DEF Containers			DEF Professional Systems	
	FF50103-D	5 Gallon Stackable Container 11.5" x 11" x 18.5"H		Versa Cart, Containers & DEF Pump Kit	
	FF75003-D	7.5 Gallon Container 11.5" x 11" x 25"H		FF31027-D	10" Tires, (2) 7.5 Gal, Pump Kit
	FF10503-D	10.5 Gallon Container 11.5" x 11" x 32"H		FF31030-D	12" Tires, (2) 7.5 Gal, Pump Kit
	FF15503-D	15 Gallon Container 14.5" x 15" x 27"H		FF31045-D	12" Tires, (2) 10.5 Gal, Pump Kit
	DEF Professional Pump Kits			DEF Pro Compact Systems	
	FF55100-D	8GPM. For FLO-FAST Containers. Includes Pump Housing, Cap, Main Draw Tube, Handle, 5' Hose, Relief Spring, Tether w/ Plug/Static Line, & Draw Tube.		Compact Versa Cart with 10" Tires, Containers & DEF Pump Kit	
	FF51505-D	8GPM For 55 Gallon Drums. Includes Pump Housing, Handle, 5' Hose, Relief Spring, Tether w/ Plug/Static Line, 3 Draw Tubes, & Bung Adaptor.		FF30125-D	(2) 5 Gal Containers (DEF)
				FF30107-D	(1) 7.5 Gal Container (DEF)
				FF30110-D	(1) 10.5 Gal Container (DEF)
				FF30150-D	(1) 15 Gal Container (DEF)
				Pour Spout for DEF	
				FF70715-D	Pour Spout with Hose, Cap, Stainless Steel Clamp, Dust Plug & Cable Tether. 3/4" ID x 1" OD x 16" L Hose

Diesel & Gasoline Transfer Packages

Diesel Carrytanks		Low Profile Diesel Carrytank	
	DSL-AFT106 106 Gallon Diesel Carrytank Forklift Pockets, Molded Handles, Lockable Cover, 12V Pump (10gpm), Auto Nozzle, 13' Delivery Hose & 13' Power Cable. 118 Lbs. 47"L x 32"W x 31"H.		DSL-AFT58LP 58 Gallon Low Profile Diesel Carrytank Forklift Pockets, Molded Handles, Lockable Cover, 12V Pump (10 gpm), Auto Nozzle, 13' Delivery Hose & 20' Power Cable. 56 Lbs. 45"L x 31"W x 17.7"H
	DSL-DEF10 Self Contained 10 Gal DEF Tank Optional Tank Nests Inside the 106 Gallon Carrytank. Includes 12V Pump, 13' Hose & Nozzle.	Low Profile Gasoline Carrytank	
	DSL-AFT58 58 Gallon Diesel Carrytank Forklift Pockets, Molded Handles, Lockable Cover, 12V Pump (10 gpm), Auto Nozzle, 13' Delivery Hose & 13' Power Cable. 56 Lbs. 36"L x 24"W x 25"H.		GAS-AGT40 40 Gallon Low Profile Gasoline Carrytank Forklift Pockets, Molded Handles, Lockable Cover, 12V Pump (10 gpm), Auto Nozzle, Fill Level Gauge, 13' Delivery Hose & 20' Power Cable. 66 Lbs. 38" W x 23" L x 18" H

FLO-FAST Systems & Accessories

Ultra-Durable Fluid Transfer for Fuel, Oil & Most Chemicals

	5 Gal Stackable Container			10.5 Gallon Container			
	FF50101	(1) Red, 11" x 11.25" x 18.5"H		FF10501	Red, 11.5" x 11" x 32"H		
	FF50103	(1) Natural, 11" x 11.25" x 18.5"H		FF10503	Natural, 11.5" x 11" x 32"H		
FF50104	(1) Yellow, 11" x 11.25" x 18.5"H		FF10504	Yellow, 11.5" x 11" x 32"H			
	7.5 Gallon Container			15 Gallon Container			
	FF75001	Red, 11.5" x 11" x 25"H		FF15501	Red, 14.5" x 15" x 27"H		
	FF75003	Natural, 11.5" x 11" x 25"H		FF15503	Natural, 14.5" x 15" x 27"H		
FF75004	Yellow, 11.5" x 11" x 25"H		FF15504	Yellow, 14.5" x 15" x 27"H			
FLO-FAST Professional Systems & Compact FLO-FAST Systems							
	FLO-FAST Professional Systems (Versa Cart 10" Tires, Containers & Pump Kit)				Compact FLO-FAST Systems (Compact Versa Cart with 10" Tires, Containers & Pump Kit)		
	FF31027-N	(2) 7.5 Gal Containers (Natural)			FF30125-R	(2) 5 Gal Containers (Red)	
	FF31015-R	(1) 15 Gal Container (Red)			FF30125-Y	(2) 5 Gal Containers (Yellow)	
	FF31015-N	(1) 15 Gal Container (Natural)			FF30125-N	(2) 5 Gal Containers (Natural)	
	FF31015-Y	(1) 15 Gal Container (Yellow)			FF30107-R	(1) 7.5 Gal Container (Red)	
FLO-FAST Professional Systems (Versa Cart 12" Tires, Containers & Pump Kit)			FF30107-Y		(1) 7.5 Gal Container (Yellow)		
	FF31030-N	(2) 7.5 Gal Containers (Natural)			FF30107-N	(1) 7.5 Gal Container (Natural)	
	FF31045-R	(2) 10.5 Gal Containers (Red)			FF30110-R	(1) 10.5 Gal Container (Red)	
	FF31045-N	(2) 10.5 Gal Containers (Natural)			FF30110-Y	(1) 10.5 Gal Container (Yellow)	
	FF31045-Y	(2) 10.5 Gal Containers (Yellow)			FF30110-N	(1) 10.5 Gal Container (Natural)	
	FF31020-R	(1) 15 Gal Container (Red)			FF30150-R	(1) 15 Gal Container (Red)	
	FF31020-N	(1) 15 Gal Container (Natural)			FF30150-Y	(1) 15 Gal Container (Yellow)	
	FF31020-Y	(1) 15 Gal Container (Yellow)			FF30150-N	(1) 15 Gal Container (Natural)	
Professional Versa Carts Foam Tires, Telescoping Handle & Steel Detachable Load Plate			Compact Versa Cart				
	FF60605	10" Tires, For (1) 15 Gal Container			10" Foam Tires, Telescoping Handle & Quick Tank Attachment. Fits all Container Sizes: (2) 5 Gallon Containers, or (1) 7.5, 10.5 or 15 Gallon Container.		
	FF60607	10" Tires, For (2) 7.5 Gal Containers					
	FF60615	12" Tires. For (1) 15 Gal Container					
	FF60617	12" Tires. For (2) 7.5 Gal Containers					
	FF60620	12" Tires. For (2) 10.5 Gal Containers					
Professional Series Pump Kits, 8GPM			Accessories				
	FF55100	8GPM. For FLO-FAST Containers. With Pump Housing, Cap, Main Draw Tube, Handle, 5' Hose, Relief Spring, Tether w/ Plug/Static Line, & Draw Tube.				FF40315	Hose Extension Kit. 3/4"ID x 5' Hose, (2) Hose Clamps & Aluminum Union.
	FF51505	8GPM For 55 Gallon Drums. With Pump Housing, Handle, 5' Hose, Relief Spring, Tether w/ Plug/Static Line, 3 Draw Tubes, & Bung Adaptor.				FF40404	Drum Extractor Ext. Kit 18" Aluminum Tube & Hose Clamp. Fits 3/4" ID Hose.
	Pour Spouts Includes Hose, Cap, Stainless Steel Clamp, Dust Plug and Cable Tether.				FF80801	Adapter, Course Thread, Fits 2" Standard Bung	
	FF70710	5/8"ID x 7/8"OD x 16"L Hose			FF80850	Filter, Aluminum, 80 Micron Screen	
	FF70715	3/4"ID x 1"OD x 16"L Hose			FF90901	Pump Holder, Aluminum, Includes Plate and Hardware	
	FF70720	1"ID x 1 1/4"OD x 16"L Hose			FF80020	Cap with Internal O-Ring.	
	Funnel Kit				FF60655	Shelf for Versa Cart with Holder for Cap & Tools.	
	FF40410	Features a 0.5" Flip-Top Cap, 40 Micron Screen, and 3" Base Opening.					





DOT Approved Refueling Tanks

Dot-Approved Tanks Up To 110 Gallons For Gasoline, Diesel, Methanol, Aviation Fuel, & Kerosene.

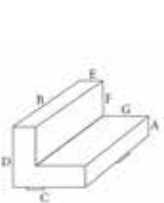
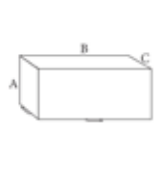

Perfect for fleets, farms, & service professionals, Aluminum Refueling Tanks are pump-ready & legal, manufactured here in the USA in 36 to 110 gallon capacities. Each Tank meets strict federal safety standards for private, commercial, and state use. DOT Approved & legal in all 50 states for on-vehicle refueling for gasoline, diesel, methanol, aviation fuel, and kerosene.

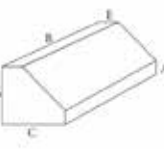
Each Refueling Tank is constructed from rugged diamond plate aluminum and comes with a 3/8"NPT drain plug, (2) 2"NPT bungs, a vent/prevent cap, and fully welded baffles to reduce slosh and add strength. Transfer Pumps are optional.

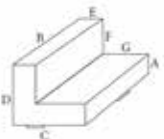
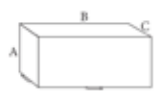



		L-Shaped Refueling Tanks Designed to pair with crossover or chest-style toolboxes, the lower L fuel tank section fits neatly beneath most standard boxes. Dual 2" bungs for flexible pump placement.		
		Part No.	Capacity	Dimensions
		ATITTL50	47 Gallons	A=9" B=36 1/4" C=28" D=18" E=9" F=9" G=19"
		ATITTL80	80 Gallons	A=9 1/2" B=48 1/2" C=28" D=26" E=8" F=16 1/2" G=20"
		ATITTL95	95 Gallons	A=9" B=48 1/2" C=33" D=26" E=11" F=17" G=22"
	ATITTL100	100 Gallons	A=9" B=60" C=31" D=24" E=9" F=15" G=22"	
		Rectangle Refueling Tanks Dual 2" bungs so you can place the fuel fill cap and optional transfer pump on the side that works best for your setup.		
		Part No.	Capacity	Dimensions
		ATITR38	38 Gallons	A=19" B=48 1/2" C=11"
		ATITR42	42 Gallons	A=12" B=48 1/2" C=19"
		ATITR43	43 Gallons	A=16 1/2" B=58" C=12"
		ATITR46	46 Gallons	A=16 1/2" B=57" C=12"
		ATITR50	50 Gallons	A=18 1/4" B=36 1/4" C=19 1/4"
		ATITR51	51 Gallons	A=23 1/2" B=60" C=9"
		ATITR55	55 Gallons	A=23 1/2" B=24 1/4" C=24"
		ATITR58	58 Gallons	A=13" B=58" C=21"
		ATITR65	62 Gallons	A=13" B=60" C=21"
		ATITR77	77 Gallons	A=19" B=57" C=18"
		ATITR110	110 Gallons	A=23 1/2" B=48 1/2" C=24"
		Wedge Refueling Tank Fits flatbeds & 5th wheel pickups with a smart 45° rear slope for better visibility and clearance. Dual 2" NPT bungs.		
		Part No.	Capacity	Dimensions
	ATITTW60	60 Gallons	A=4" B=56" C=20" D=18" E=6"	
		Split Refueling Tanks Two tanks in one system to transport & dispense two fuels safely. Constructed from rugged, fully welded diamond plate aluminum with dual 2" NPT bungs.		
		Part No.	Capacity	Split Tank Dimensions
		ATITTL85S	85 Gallons	A=9" B=57" C=30" D=24" E=9" F=15" G=21", (42 Gal./42 Gal.)
		ATITTL95S	95 Gallons	A=9" B=48 1/2" C=33" D=26" E=11" F=17" G=22", (47 Gal./47 Gal.)
		ATITR72S	72 Gallons	A=18" B=57" C=18", (36 Gal./36 Gal.)
		ATITR110S	110 Gallons	A=23 1/2" B=48 1/2" C=24", (55 Gal./55 Gal.)

Note: Mounting Tabs Extend out 1 1/2". Add 2 1/2" for Cap Height.

DOT Approved Refueling Tanks



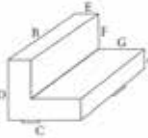

Dot-Approved Tanks Up To 110 Gallons For Gasoline, Diesel, Methanol, Aviation Fuel, & Kerosene.



 		Double Wall Refueling Tanks Extra protection while maximizing capacity in a compact, rectangle design. Each tank includes dual 2" NPT bungs.			
Part No.	Capacity	Dimensions			
ATITTR98DW	98 Gallons	A=25" B=48" C=26"			
ATITTR110DW	110 Gallons	A=25" B=53" C=26"			
 		Refueling Tank & Toolbox Combos This all-in-one solution features polished stainless locking handles, gas shocks, reinforced three-layer lid, full aluminum piano hinge, and an aero-beveled design			
Part No.	Capacity	Tank Dimensions		Toolbox Dims.	
ATITTR42CB	42 Gallons	A=21" B=48 1/2" C=19"		36" x 19" x 9"	
ATITTR58CB9	58 Gallons	A=21" B=58" C=21"		42" x 19" x 9"	
ATITTL50CB	47 Gallons	A=18" B=36 1/4" C=29"		36" x 19" x 9"	
ATITTL95CB	95 Gallons	A=26" B=48 1/2" C=33"		48" x 22" x 17"	
 		Severe Series Refueling Tanks Built for extreme conditions and heavy-duty use with 50% thicker, .190" aluminum, the tanks handle larger pumps with internal pump bung support for dual 2" bungs, a lockable Spin Secure Cap, welded baffles, and rollover-protected vent.			
Part No.	Capacity	Dimensions			Toolbox Dims.
ATISSL95	95 Gallons	A=9" B=48 1/2" C=33" D=26" E=11" F=17" G=22"			N/A
ATISSL95CB	95 Gallons	A=26" B=48 1/2" C=33"		48" x 22" x 17" .063 HD Toolbox	
ATISSR110	110 Gallons	A=24" B=48 1/2" C=24"		N/A	









Note: Mounting Tabs Extend out 1 1/2". Add 2 1/2" for Cap Height.

Refueling Transfer Pumps

12V 20GPM Automatic Nozzle	12V 15GPM Automatic Nozzle	12V 15GPM Manual Nozzle	12V 8GPM Manual Nozzle	Deluxe Dual Flow Hand Pump, 50 Gal/100 Strokes
ATIBSG20012AD	ATIBSM150SAU	ATIBSM150SMU	ATIBSEZ8	ATIBSHP100UL
				



TransCube & FuelCube Fuel Tanks

Refuel Machinery On-Site with Transportable Double Wall Tanks

TransCube Global Mobile Refueler				
	DSLH10TCG-EB	TransCube Global Mounted on a DOT Approved Galvanized Trailer with Backlights and Electric Brakes.	251 Gallon	75"W x 143"L x 74"H
	DSLH20TCG-EB		552 Gallon	85"W x 165"L x 75"H
TransCube Global				
	DSLTCGWN0010	Features a Lockable Cabinet That Secures Equipment and Ports, with Hose Access. Standard Fittings: Fluid Gauge, 2" Fusible Link Fill Port, 3" Fill Point, Pressure/Vacuum Vent, Breather Vent, Engine Feed & Return Port Set, 1" Pump Feed w/ Flexible Dip Pipe, Strainer & Non-Return Valve.	251 Gallons	45"W x 45"D x 52"H
	DSLTCGWN0020		552 Gallons	90"W x 45"D x 52"H
	DSLTCGWN0050		1,242 Gallons	91"W x 91"D x 52"H
FuelCube				
	DSLFCPWN0119	Includes 4-Way Forklift Pockets, and a Fuel Gauge Inside the Lockable Cabinet Standard Fittings: 1" Pump Feed, Vent & Fill Cap.	119 Gallons	46"W x 46"D x 32"H
	DSLFCPWN0250		243 Gallons	45"W x 45"D x 51"H
	DSLFCPWN0500		528 Gallons	86"W x 45"D x 51"H
	DSLFCPWN1000		1,016 Gallons	90"W x 87"D x 46"H
	DSFCPWN1800		1,862 Gallons	156"W x 87"D x 46"H
FuelCube Diesel Packages				
	DSLFCPWN011901215GPSNN	Includes FuelCube, 12V/15GPM Diesel Pump and Fuel Level inside the Lockable Cabinet. Standard Fittings: 1" Pump Feed, Vent & Fill Cap.	119 Gallons	46"W x 46"D x 32"H
	DSLFCPWN025001215GPSNN		243 Gallons	45"W x 45"D x 51"H
	DSLFCPWN050001215GPSNN		528 Gallons	86"W x 45"D x 51"H
	DSLFCPWN100001215GPSNN		1,016 Gallons	90"W x 87"D x 47"H
FuelCube Gasoline Packages				
	DSLFCPWN025011512GPSNNG	Includes FuelCube, 115V/12GPM Gasoline Pump and Fuel Gauge inside the Lockable Cabinet, and an Emergency Vent Kit. Standard Fittings: 1" Pump Feed, Vent & Fill Cap.	243 Gallons	45"W x 45"D x 51"H
	DSLFCPWN050011512GPSNNG		528 Gallons	86"W x 45"D x 51"H
	DSLFCPWN100011512GPSNNG		1,016 Gallons	90"W x 87"D x 46"H
Accessories for TransCube and FuelCube				
	DSLWGHRSR1225SW	Hose Reel	3/4" x 25' Spring Retractable Hose Reel w/ Soft-Walled Hose & Hose Stop. Requires Hose Reel Mounting Bar Kit	
	DSLWGTCGBRKT	Side Mount	Use with 251 Gallon TransCube Global & TransCube Mobile Refueler	
	DSLWGSBKTCG		Use with 552 Gallon TransCube Global & TransCube Mobile Refueler	
	DSLWGFCPBRKT	Accessory Bracket	Use with 119 & 243 Gallon FuelCube	
DSLWGSBKFCP	Use with 528, 1,016 & 1,852 Gallon FuelCube			
	DSL150S	Standard Pump Kits	12V / 15GPM 3/4" Pump Kit Includes Mounting Kit, Inlet Fittings, 12' Hose & Auto Nozzle. 18"W x 18"D x 12"H, 40 Lbs.	
	DSL1115		115V / 12GPM 3/4" Pump Kit Includes Mounting Kit, Inlet Fittings, 12' Hose & Auto Nozzle. 18"W x 18"D x 12"H, 40 Lbs.	
	DSL150D	Deluxe Pump Kits	12V / 15GPM 3/4" Pump Kit Includes Mounting Kit, Inlet Fittings, 12' Hose, Auto Nozzle, Inline Meter, Swivel & Filter Kit. 24"W x 18"D x 13"H, 50 Lbs.	
	DSL1115D		115V / 12GPM 3/4" Pump Kit Includes Mounting Kit, Inlet Fittings, 12' Hose, Auto Nozzle, Inline Meter, Swivel & Filter Kit. 24"W x 18"D x 13"H, 50 Lbs.	
	DSLPWK03016	Particulate & Water Filter Kit	30 Micron 1" Input/Output (25GPM) 1 3/8" Filter Thread.	





Smart Ass Fuel Mule Motorized Gas Caddy

Transport & Dispense Fuel With The Motorized Gas Caddy That Handles Tough Terrain, Ramps, & Tight Spaces.











	Part#	Description	Capacity	Dims.	WT.	Features
	SAFM810001A	Smart Ass Fuel Mule	50 Gallon	39.5"L x 30"W x 42"H	280 Lbs.	<ul style="list-style-type: none"> • 15 GPM Ele Pump & Auto Shutoff Nozzle • 750w Brushless 24v Motor • Hydraulic Disc Brakes • Off-Road Tires • Rechargeable Battery
	SAFM810001B	Smart Ass Fuel Mule Flatlander	70 Gallon	39.5"L x 30"W x 46"H	310 Lbs.	
	SAFM810005A	Smart Ass Fuel Mule Aviation Ed.	50 Gallon	39.5"L x 30"W x 42"H	300 Lbs.	Aviation Features In Addition To Same Features Above (Pump, Motor, Brakes, Tires & Battery)
	SAFM810005B	Smart Ass Fuel Mule Flatlander Aviation Ed.	70 Gallon	39.5"L x 30"W x 46"H	330 Lbs.	
	SAFM810020A	Smart Ass Cargo Mule, Motorized Material Handling Chassis		26" x 30"	220 Lbs.	<ul style="list-style-type: none"> • Utility & Customization In Mind • Payload ~450 Lbs (Flat Ground) • 750w 24v Motor Platform • Hydraulic Disc Brakes • Mounting Holes Secures Equipment • 50mm Through-Hole Flatbed Grid • Hook Eyes For Tie Down

Battery Operated Pumps

Transfer Up To 40 Gallons with One Powerhead Across Multiple Fluids.

Battery Operated Powerhead Starter Kits			Battery Operated Stem Kits		
Includes Powerhead, Stem Kit, Adjustable Suction Tube, 5ft Hose with Nozzle, 18V Battery, and Battery Charger.			Includes Adjustable Suction Tube, 5ft Hose with Nozzle, and Stem Extender.		
	FHMBP205S-DUNU	Powerhead Starter Kit For 16-55 Gallon Drums Use with DEF, Oil to 140W, Coolant, & ATF. Stainless Steel Stem Resists DEF Corrosion.		FHMBP205X-DUNA	Stem Kit For 16-55 Gallon Drums Use with DEF, Oil to 140W, Coolant, & ATF. Stainless Steel Stem Resists DEF Corrosion.
	FHMBP205S-UNU	Powerhead Starter Kit For 16-55 Gallon Drums Use with Oil to 140W, Coolant, & ATF.		FHMBP205X-UNA	Stem Kit For 16-55 Gallon Drums Use with Oil to 140W, Coolant, & ATF.
	FHMBP20S-UNU	BOP20 Powerhead Kit For 5 Gallon Pails Use with Oil to 140W, Coolant, & ATF.		FHMBP20X-UNA	BOP20 Stem Kit For 5 Gallon Pails Use with Oil to 140W, Coolant, & ATF.













Battery Operated Pump Accessories

	FHMBP20-PH	BOP Powerhead		FHMBP-HG	5ft x 3/4" Hose & Nozzle		FHMBP-1K	Impeller & Seal Kit For Oil, Coolant, & ATF Fluids. Do Not Use With DEF.
	FHMBPC-U	Battery Charger Charges 45 min.		FHMBP-HG3	10ft x 3/4" Hose & Nozzle		FHMBP-4K	Impeller & Seal Kit For DEF & Oil/Coolant/ATF.
	FHMBPB-20AH	Rechargeable Li-Ion Battery 2.0Ah, 18V, 36Wh		FHMBP-HK	5ft Hose & Barb Replacement		FHMBP20-AK	Bung Adapter Set for BOP20
				FHMBP-HK3	10ft Hose & Barb Replacement		FHMBP60-AK	Bung Adapter for BOP205



Fluidall Exclusive Pump Packages & Equipment

Fluidall Exclusive Pumps and Equipment deliver steady, reliable performance your shop can count on. Available in 3:1 or 5:1 ratios, they keep fluids moving with precise, controlled output. The non-corrosive, oil free air motor runs clean and efficient with low air use and quiet operation. Built in pressure relief protects against thermal expansion, and every pump is backed by a 10 year warranty. Ready for oils and lubricants, these pumps are tough, dependable, and built to keep up with your workload.

Pneumatic Pump Packages		
	FHF3150PM	3:1 Preset Pump Package Includes 3:1 T312 Pump, Hose Reel 1/2" x 50ft, M3 Preset Dispense Gun, M3 Air Pressure Regulator, Oil Lead Hose 5ft 1/2" FS x M, and Bushing 3/4" x 1/2".
	FHF3150MM	3:1 Non-Preset Pump Package Includes 3:1 T312 Pump, Hose Reel 1/2" x 50ft, M3 Non-Preset Dispense Gun, M3 Air Pressure Regulator, Oil Lead Hose 5ft 1/2" FS x M, and Bushing 3/4" x 1/2".
	FHF5150PM	5:1 Preset Pump Package Includes 5:1 T512 Pump, Hose Reel 1/2" x 50ft, M3 Preset Dispense Gun, M3 Air Pressure Regulator, and Oil Lead Hose 5ft 1/2" FS x M.
	FHF5150MM	5:1 Non-Preset Pump Package Includes 5:1 T512 Pump, Hose Reel 1/2" x 50ft, M3 Non-Preset Dispense Gun, M3 Air Pressure Regulator, and Oil Lead Hose 5ft 1/2" FS x M.
Pneumatic Oil Pumps & Dispense Equipment		
	FHF312OP	3:1 Air Operated T312 Oil Pump with Bung Adapter
	FHF512OP	5:1 Air Operated T512 Oil Pump with Bung Adapter
	FHFM39P	M3 Preset Dispense Gun 9 GPM
	FHFM39M	M3 Non-Preset Dispense Gun 9 GPM
	FHF1250HR	M3 Industrial Grade Hose Reel 2320 PSI, 1/2" x 50ft Hose
	FHFM3APR	M3 Air Pressure Regulator 1/4" with Gauge
	FHF512OH	Oil Lead Hose 5ft 1/2" FS x M
	FHF3412B	Bushing 3/4" x 1/2"





Samson Pumps & Dispense Equipment

Pneumatic Pump Packages			Pumps & Dispense Equipment		
	FHS1100OPP	PumpMaster 2 (Preset Package) 3:1 PumpMaster Oil Pump with 50' Reel, Preset Meter, Air Pressure Regulator		FHS353120	PumpMaster 2 3:1 Samson Universal Oil Pump with Bung Adapter
	FHS1100OPM	PumpMaster 2 (Non-Preset Package) 3:1 PumpMaster Oil Pump with 50' Reel, EC8 Non-Preset Meter, Air Pressure Regulator		FHS347120	PumpMaster 4 5:1 Samson Universal Oil Pump with Bung Adaptor
	FHS900341	PumpMaster 2 (Non-Preset Package) 3:1 PumpMaster Oil Pump, 2" NPTM Bung, 40' 1400 Series Medium Pressure Reel, EC8 Non-Preset Meter, Air Regulator, Quick Air Coupler and Nipple.		FHS332120	Coolant/Washer Fluid 1:1 Air Operated Pump , 1" NPTF Bung. Not Suitable for Use with DEF. 14.5 gpm.
	FHS900542	PumpMaster 4 (Non-Preset Package) 5:1 Oil Pump, 2" NPTM Bung, 50' 504 Series Reel, EC8 Non-Preset Meter, Air Pressure Regulator, Quick Air Coupler and Nipple.		FHS504250	504 Series Hose Reel with 1/2" x 50' Hose
	FHS900542	PumpMaster 4 (Non-Preset Package) 5:1 Oil Pump, 2" NPTM Bung, 50' 504 Series Reel, EC8 Non-Preset Meter, Air Pressure Regulator, Quick Air Coupler and Nipple.		FHS504150	Air/Water Hose Reel with 1/2" x 50' Hose
	FHS900543	PumpMaster 4 (Preset Package) 5:1 Oil Pump, 2" NPTM Bung, 50' 504 Series Reel, Preset Meter, Air Pressure Regulator, Quick Air Coupler and Nipple.		FHS506222	506 Series Hose Reel
	FHS900544	PumpMaster 4 (Preset Digital Package) 5:1 Oil Pump, 2" NPTM Bung, 50' 504 Series Reel, Preset Digital Meter, Air Pressure Regulator, Quick Air Coupler and Nipple.		FHS365316	Electronic Preset Meter , Rigid Ext., 8GPM
	FHS1000CP	Anti-Freeze/Washer Fluid Package Samson 1:1 Pump, 50' Hose Reel, Non-Metered Control Handle, Air Pressure Regulator.		FHS365536	EC8 Electronic Non-Preset Meter , Rigid Ext., 8GPM
Side Mount Shelf Packages				FHS363116	CV11 Non-Metered Dispense Handle Rigid Ext. Quarter Turn Non-Drip Tip, 11GPM
				FHS363117	CV11 Non-Metered Dispense Handle , Formable Ext. Quarter Turn Non-Drip Tip, 11GPM
SMTS Packages: Samson 3:1 PumpMaster Oil Pump, Hose Reel with 50' Hose, Preset or Non-Preset Meter, Air Pressure Regulator, 3 Way Brass Ball Valve, Tank Mounted Gun Holder, SMTS Shelf, Hoses & Components. Use w/ Large Tote-A-Lube Tanks and Cubetainer Tanks (Excluding 60 Gal. Cubetainer).				FHS970	1/4" Air Regulator with Gauge
				FHS956	1/4" Filter Regulator with Gauge, Auto Drain
				FHS957	3/8" Filter Regulator with Gauge, Auto Drain
Portable Drum Package				FHS211001	PumpMaster 2 3:1 55 Gallon Portable Drum Package Includes 3:1 Pump, 1/2" x 30' Hose Reel, Metered Handle, 1/4" Quick Air Coupler, 1/4" Quick Air Nipple, 1/4" Filter Regulator, and Heavy Duty Cart

GRACO® Graco Pumps & Dispense Equipment









Pneumatic Pump Packages			Side Mount Shelf Packages					
	FHG24K834	3:1 LD Pump, 35' SD Reel, EM Manual Meter, Air Pressure Regulator	3:1 LD Pump, 50' SDX Reel, Non-Preset EM Manual Meter or LDP5 Preset Meter, Air Pressure Regulator, 3 Way Brass Ball Valve, Tank Mounted Gun Holder, SMTS Shelf, Hoses & Components. Use w/ Large Tote-A-Lube Tanks and Cubetainer Tanks (Excluding 60 Gal. Cubetainer).					
	FHG24K797	3:1 LD Pump, 50' SD Reel, EM Manual Meter, Air Pressure Regulator						
	FHG24K777	3:1 LD Pump, 50' SD Reel, LDP5 Preset Meter, Air Pressure Regulator		SMTS-PKP	Preset SMTS Package			
	FHG24V207	3:1 LD Pump, 75' SD Reel, EM Manual Meter, Air Pressure Regulator		SMTS-PKM	Non-Preset SMTS Package			
	FHG24V208	3:1 LD Pump, 75' SD Reel, LDP5 Preset Meter, Air Pressure Regulator	Double Diaphragm Pumps					
	FHG24K798	5:1 LD Pump, 50' SD Reel, EM Manual Meter, Air Pressure Regulator					FHG241906	Husky 716 Air Operated Dbl Diaphragm Pump, 3/4" Connection. 15 gpm.
	FHG24K796	5:1 LD Pump, 50' SD Reel, LDP5 Preset Meter, Air Pressure Regulator					FHG647016	Husky 1050 Air Operated Dbl Diaphragm Pump, 1" Connection & Aluminum Housing. 50 gpm.

Fire-Ball Pump Packages			Drum Lever Pump		
	FHG224541	5:1 Fire-Ball 300 Pump, 50' SD Reel, SDM5 Manual Meter, Air Pressure Regulator		FHG114829	Lever Pump For 16 & 55 Gal Drums. For Oils and Antifreeze.
	FHG244038	5:1 Fire-Ball 300 Pump, 50' SD Reel, SDP5 Preset Meter, Air Pressure Regulator			

Pneumatic Pumps & Dispense Equipment								
	FHG24G576	3:1 LD Series Pump with Bung Adapter		FHG25C903	EM Series Manual Meter Rigid Extension, 8gpm		FHG25M417	SDM18 Manual Flexible Extension, 18gpm
	FHG24G588	5:1 LD Series Pump with Bung Adapter						
	FHG203876	5:1 Fire-Ball 300 Pump		FHG256216	LDP5 Preset Rigid Extension, 5gpm		FHG24Z125	SD Series Mechanical Meter Preset Rigid Extension, 8gpm
	FHGSDM33B	SDX Series Reel 1/2" x 35' Hose		FHG258694	LDP5 Preset Flexible Extension, 5gpm		FHG24V037	SD Series Mechanical Meter Manual Rigid Extension, 8gpm
	FHGSDM65B	SDX Series Reel 1/2" x 50' Hose						
	FHGSMC8B	XD Series Reel 1/2" x 75' Hose						
	FHGHSM5B	XD Series Reel 3/4" x 50' Hose		FHG26C384	SDP8 Preset Rigid Extension, 8gpm		FHG24V034	SD Series Mechanical Meter Manual Flexible Extension, 8gpm
FHGSDL65B	SD Series Air & Water Reel 1/2" x 50' Hose, 300 PSI	FHG26C356		SDP18 Preset Rigid Extension, 18gpm				









Samson Grease Pump Packages & Accessories





























	FHS319	PM3 55:1 35 Lb Portable Grease Package with 5' Hose		FHS305101	PM3 55:1 400 Lb Stationary Grease Package with 20' Hose
	FHS303101	PM3 55:1 120 Lb Stationary Grease Package with 10' Hose		FHS305161	PM3 55:1 400 Lb Portable Grease Package with 20' Hose, Standard-Duty Platform Truck
	FHS320	PM3 55:1 120 Lb Portable Grease Package with 5' Hose		FHS311001	PM35 60:1 400lb Portable Grease Package with 30' Hose
	FHS303141	PM3 55:1 120 Lb Portable Grease Package with 10' Hose, Band Dolly		FHS413080	High Pressure Grease Control Handle



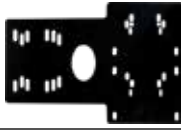









Graco Grease Packages & Accessories

	GHG225006	Fire-Ball 300 Series 50:1 120 Lb. Portable Grease Package, Caster Base. Includes Fire-Ball Pump, Dispense Kit, Zinc Plated Steel Z-Swivel, Dispense Valve. Requires Air Regulator FHG109075.		GHG225016	Fire-Ball 300 50:1 400 Lb. Stationary Grease Package. Includes Fire-Ball Pump, Hose Kit, Cover & Follow Plate. Requires Dispense Gun & Air Regulator FHG109075.
	GHG225026	Fire-Ball 300 Series 50:1 120 Lb. Portable Grease Package, 2-Wheel Cart. Includes Fire-Ball Pump, Dispense Kit, Zinc Plated Steel Z-Swivel, Dispense Valve. Requires Air Regulator FHG109075.		GHG222070	12' Grease Hose Kit Use with Fire-Ball 300 Pump. Includes Air Coupler, Air Nipple, Grease Dispense Valve & Z-Swivel.
	GHG222245	Fire-Ball 300 Series 50:1 120 Lb. Portable Grease Package, Heavy Duty Cart. Includes Fire-Ball Pump, Zinc Plated Steel Z-Swivel, Hold Down Kit & Dispense Valve. Requires Air Regulator FHG109075.		GHG222383	25' Grease Hose Kit Use with Portable Grease Packages Powered by Fire-Ball 300 or Mini Fire-Ball 225. Includes Air Coupler, Air Nipple, Grease Dispense Valve & Z-Swivel.
	GHG225014	Fire-Ball 300 Series 50:1 120 Lb. Stationary Grease Package. Includes 50:1 Fire-Ball Pump, Hose Kit, Cover & Follow Plate. Requires Dispense Gun & Air Regulator FHG109075.		GHG242056	High Pressure, HD Valve 1/4" NPT Inlet w/ Coupler & Extension. Handles up to NLGI #2 Grease.

Oil Bars & Dispense Accessories

Oil Bars		Air Pressure Regulators	
	OT3	Oil Bar, Triple Dispense Valves Removable Drip Tray 31"W x 15"D x 24"H	 FHG24H420 Mini, 1/4" with 3/8" Adapter.
	OT3M	Metered Oil Bar, Triple Dispense Valves Removable Drip Tray 31"W x 15"D x 24"H	 FHG109075 3/8" with Gauge.
 FHG110147			1/4" with Gauge. For Husky 515 DDP
 FHG244844			1/2" with Gauge. For Husky 1050 DDP
Side Mount Dispense		Misc. Accessories	
	SMTS-PK	Pump/Reel Shelf Kit: 3 Way Brass Ball Valve, Tank Mounted Gun Holder, Pump/Reel Shelf, Hoses & Components. Dispense Pkg. NOT Included. Use w/ Large Tote-A-Lube Tanks and Cubetainer Tanks (Excluding 60 Gal. Cubetainer).	 FHG24F910 Bracket, Wall Mount For Graco LD Pumps
	SMTS	Pump/Reel Shelf (Steel) Use w/ Large Tote-A-Lube Tanks and Cubetainer Tanks (Excluding 60 Gal. Cubetainer).	 FHWMPKIT1 Wall Mount Kit 8' Hose, Bracket, 90° Elbow. For Graco LD Pumps.
	SMTPB-PK	Pump Shelf Kit: 3 Way Brass Ball Valve, Pump Shelf, Hoses and Components. Dispense Package NOT Included. Use w/ Large Tote-A-Lube Tanks and Cubetainer Tanks (Excluding 60 Gal. Cubetainer).	 FFUIY5502F1616 90° Steel Elbow for Graco Pumps
	SMTPB	Pump Shelf (Steel) Use w/ Large Tote-A-Lube Tanks and Cubetainer Tanks (Excluding 60 Gal. Cubetainer).	 FHG222308 Bung Adapter For Fire-Ball 300 Pump with Hardware
	SMRS	Universal Side Shelf, Steel for 32" Tanks Mounts (1) Pump & (1) Reel	 FHDKDGH Gun Holder Tank Mount
	SMRL	Universal Side Shelf, Steel for 42" Tanks Mounts (1) Pump & (1) Reel	 FHBVN100 Banjo 1" Polypro Nozzle , Rigid Extension, 40gpm
	SMRLSS	Universal Side Shelf with (2) Legs , Mounts (2) Pumps & (2) Reels. 42"L x 36"H. Use with 32" Tote-A-Lube Tanks	 FHG120581 4-Way Evac Valve 1" NPT, 200 PSI, 4.75"
Top Mount Dispense		 FHG24J495 Graco Air/Oil Hose Kit 6' x 3/8" Air Hose, 6' x 1/2" Oil Hose, with Adapter and Swivel	
	HRP-C	Hose Reel Plate Use with T120, T130, T180, T240 or T330	 FH1202MM Hose, 2' with 1/2" M Swivel & 1/2" M Fixed
	HRP-CD	Diaphragm Pump & Reel Plate , Use with T120, T130, T180, T240 or T330	 FH1203MM Hose, 3' with 1/2" F Swivel & 1/2" M Fixed
	FHG24F930	IBC Tote Top Mount Bracket for LD Pump Mounts LD Series Pump on Top of IBC Tote.	 FH1206 Hose , 2500 PSI, 6' FH1212 2500 PSI, 12' FH1215 2500 PSI, 15' FH1220 2500 PSI, 20'
	FHG24K285	IBC Tote Mount Bracket for SD Hose Reel Mounts SD Series Hose Reel to IBC Tote	 FHG24C538 Hose, 1/2" x 2' w/ 90 For Graco LD Pump to Reel, 1,800 PSI
			 FH1002 Oil Hose 1" x 2' FH1030 1" x 30" FH1004 Draw Side 1" x 4' FH1006 1" x 6' FH1008 1" x 8'

Automotive Service Equipment

Stands, Jacks & Lift Equipment				
	MSP4858010700	7 Ton Support Stand – High Rise	14,000 lb Capacity Weight: 105 lb	Start Height: 53.1" Lift Height: 72.1"
	MSP4858010900	10 Ton Support Stand – High Rise	20,000 lb Capacity Weight: 115 lb	Start Height: 53.4" Lift Height: 72.1"
	MSP4858001000	25 Ton Support Stand	50,000 lb Capacity Weight: 62 lbs (pair)	Start Height: 12" Lift Height: 20"
	MSP4858001100	25 Ton Tall Support Stand	50,000 lb Capacity Weight: 112 lbs (pair)	Start Height: 20" Lift Height: 32"
	MSP4858002500	Automotive Transmission Jack	Power: Air/Hydraulic 1,000 lb Capacity	Start Height: 34.5" Lift Height: 72"
	MSP4858003100	Commercial Transmission Jack	Power: Manual/Hydraulic 2,200 lb Capacity	Start Height: 8" Lift Height: 34"
	MSP4858003300	CML Transmission Jack (Air Assist)	Power: Air/Hydraulic 2,200 lb Capacity	Start Height: 8" Lift Height: 34"
	MSP4858002400	6 Ton Service Jack (Air Assist)	Power: Air/Hydraulic/Manual 12,000 lb Capacity	Start Height: 4.8" Lift Height: 23.3"
	MSP4858002300	10 Ton Service Jack (Air Assist)	Power: Air/Hydraulic/Manual 20,000 lb Capacity	Start Height: 7" Lift Height: 27"
	MSP4858005100	Commercial Vehicle 25 Ton Axle Jack	Power: Air/Hydraulic 50,000 lb Capacity	Start Height: 8" Lift Height: 21"
	MSP4858001700	10 Ton Air Lift & Support Stand	Power: Air/Hydraulic/Manual 20,000 lb Capacity	Start Height: 17.5". Lift Ht w/ EXT: 52.5" w/out EXT: 37.5"
	MSP4858001800	15 Ton Air Lift & Support Stand	Power: Air/Hydraulic/Manual 30,000 lb Capacity	Start Height: 17.6". Lift Ht: w/ EXT: 52.3" w/out EXT: 37.3"
	MSP4858011400	1,500 lb Wheel Dolly	Power: Hydraulic 1,500 lb Capacity	Lift Height: 8"
	MSP4858009400	7 Ton Wireless Mobile Column Lift	Weight: 1,485 lb (Ea) Capacity: 14,000 lb (Ea) / 56,000 lb (Set of 4)	Wheel Diameter: 5" Min/24.5" Max
	MSP4858009500	7 Ton Wireless Mobile Column Lift (Set of 4)		
	MSP4858009800	9 Ton Wireless Mobile Column Lift	Weight: 1,510 lb (Ea) Capacity: 19,000 lb (Ea) / 76,000 lb (Set of 4)	Lift Height: 32" Min/69" Max
	MSP4858009900	9 Ton Wireless Mobile Column Lift (Set of 4)		
Oil Filter Crushers				
	MSP4858008200	CML Oil Filter Crusher with 16.3"H x 10"W x 8"D Crushing Chamber	Stand Dims: 61"H x 29"W x 27"D / Dims: 85.5" x 20.5" x 16.8" Air Inlet: 1/4 Female NPT Air Pressure: 100 to 200 psi (6.9 to 13.8 bar) Catch Basin Connection: 3/4 Female NPT / Ship WT: 282 lb	
	MSP4858008100	Auto Oil Filter Crusher with 9"H x 8"W x 8"D Crushing Chamber	Stand Dims: 57"H x 29"W x 23"D / Dims: 69.5" x 15" x 16.8" Air Inlet: 1/4 Female NPT Air Pressure: 100 to 160 psi (6.9 to 11.0 bar) Catch Basin Connection: 3/4 Female NPT / Ship WT: 242 lb	

Automotive Service Equipment

	Shop Exhaust Ventilation System	
	MFP4358000100	FluidPRO EV-1
	System Features <ul style="list-style-type: none"> • Powerful .75 HP motor • Low noise rating • Heat-resistant hose • Corrosion-resistant fan • Adjustable height 	Specifications <ul style="list-style-type: none"> • Flow Capacity: 270 CFM (460 CMH) • Fuses: Qty. 2; 16 Amp time delayed • Hose: 40 ft x 5" diameter • Motor: 110 VAC (0.75 HP) • Power Source: Minimum 6 Amp
	Brake Fluid Exchange Systems	
	MFP4258001400	FluidPRO BFX-20 Includes Adapters
	MFP4258001100	FluidPRO BFX-20 Adapters NOT Included
	System Features <ul style="list-style-type: none"> • Compatible with ABS, ESP, EDS, & SBC systems • Pulsating flow removes air from braking system • Operator control via mobile device • Automatic switch-off on empty container • Pressureless decoupling from vehicle • BFX PLUS fluid extraction system • Variable pressure regulator • Hydraulic pump • Removable tool tray 	Specifications <ul style="list-style-type: none"> • Working Pressure: 5-50 psi • Weight: 46 lbs • Power Supply: 110V, 60Hz • Dimensions: 16"L x 16"W x 40"H • Filling Hose Length: 11.3 ft • Max. Container Size: 5L / 1.3 gal
	Transmission Fluid Exchange System	
	MFP4008002300	FluidPRO ATX-280
	System Features <ul style="list-style-type: none"> • Built-in 40+ year vehicle spec database • Automatic oil flow direction detection • Onboard additive tank for precise injection • Zero cross contamination process • Auto-start at optimal oil temperature • Interchangeable tank with 10-sec swap • Exchange service of 2-5 min. / 6-10 min. in Dipstick mode 	Specifications <ul style="list-style-type: none"> • Includes standard adapter kit • 7" touch screen LCD display • 25 qt. ea tank - both new & used fluids • 10ft service hoses, 5ft. drain hose, 5 ft clear + 5 ft black dipstick mode • 2x variable speed hydraulic oil pumps • Process time 2 to 5 minutes • Dimensions: 47"H x 29"W x 29"D • Weight 136 lbs.
	Vacuum Coolant Exchange Systems	
	MFP4708001900	FluidPRO VCX-1 (2) 20 Qt. Cylinders: (1) Waste, (1) New. 166 lbs.
	MFP4708002000	FluidPRO VCX-4 (4) 20 Qt. Cylinders: (1) Waste, (3) New. 200 lbs.
	System Features <ul style="list-style-type: none"> • Quick coolant changeover for most vehicles • Service cycles of 5-15 minutes • No-Leak End Cap Design • Vacuum Gauge • Pressure Relief Valve 	<ul style="list-style-type: none"> • Dimensions: 63" x 28" x 22.5" • 2 Cone plugs & 8in hose adapter • Ball valve controls with color-coded system • 10ft Hose • Venturi vacuum pump, max 28 inHg (0.95 bar) • Shop air, 55-110 psi
	Multi-Coolant Fluid Exchange Systems	
	MFP4708003000	FluidPRO MCX-2 Includes system pressure test with hot cap release
	MFP4708003100	FluidPRO MCX-2 With a flush bypass loop & flow indicator
	System Features <ul style="list-style-type: none"> • Universal step and hose adapters • Coolant Exchange 92 to 98% single pass • Dimensions 45"H x 38"W x 22.5"D • (2) 7.5 gal new coolant tanks • Hoses 3/8"; quick connect/disconnect 	<ul style="list-style-type: none"> • Power Source 12 VDC - 15 Amp • Pressure Switch 6 to 12 psi (0.4 to 0.8 bar) • Full exchange in under 3 minutes • Pumps 2 gal. per minute







Refrigerant Handling Systems

Reliable Charging and Recovery for R134a & R134yf



	R134a Part#	Model	ArticPRO Features	R134a Model Specific Features
	MAP4608044500	ArticPRO ACX2150	<ul style="list-style-type: none"> 7" Touch Screen & Intuitive User Interface Automatically Weighs Recovered Oil Bright LED Indicator Light Data Tracking & Reporting 	<ul style="list-style-type: none"> Works with the older, common refrigerant (R134a) Has UV dye injection to help find leaks Ideal for everyday use in smaller shops
	MAP4608044700	ArticPRO ACX2180		<ul style="list-style-type: none"> Compatible with R134a & UV dye for leak detection Three sensors for faster cycle times Ideal for busy shops that want to save time
	MAP4608044800	ArticPRO ACX2180H		<ul style="list-style-type: none"> R134a compatible with UV leak detection Three sensors for faster cycle times Safe for hybrid & electric vehicle A/C systems
	R134yf Part#	Model	R134yf Model Specific Features	
	MAP4608044600	ArticPRO ACX2250	<ul style="list-style-type: none"> Supports R1234yf (2017+ vehicles) Refrigerant safety test prevents contamination Network printing capability & PDF emailing capabilities 	
	MAP4608044900	ArticPRO ACX2280	<ul style="list-style-type: none"> VIN auto-pull, POE oil compatibility Best for high-end, high-volume modern shops Network printing capability & PDF emailing capabilities 	

Battery Starters & Analyzers

Professional-Grade Charging Power Built for the Shop





	Part No.	Description	Voltage / Cont. Charging Amps	Crank Assist / Boost	Battery Types	Display / Controls	Special Modes / Features
	BSUS20A	6/12 Volt Professional Fast Wheel Charger, Safe for Sealed Lead Acid Batteries	6/12 V 40 A	200 A	SLA	Analog Meter, Timer	Fan Cooling, DIY-Friendly
	BS612AGMA	6/12 Volt Professional Fast Wheel Charger, Safe for AGM & Sealed Lead Acid Batteries	6/12 V 70/60/30 A	250 A	SLA, AGM	Analog Meter, Timer	Safe for AGM
	BS6021AGMA	6/12/24 Volt HD Fleet Charger/Analyzer, Safe for AGM & EFB Batteries	6/12/24 V 70/65/30 A	205 A	SLA, AGM, EFB	Digital Meter (Amps/ Volts/ Time/ Mode)	Battery Tester & Analyzer, Dead Battery Override, AGM/EFB Specialty Charge, Auto Restart
	BS6002BA	6/12/18/24 Volt Wheel Charger with Start	6/12/18/24 V 100/80/50/40 A	400 A	SLA	Analog Meter, Timer	Patented Flexi-Spring, Stop/Go Light
	BSIBC6008MSKA	12V, 60/70A Intelligent Wheel Charger/Relash Power Supply, Safe for All Battery Types SLA, AGM, EFB, Gel, Lithium-Ion.	12 V 60 A Adjustable	270 A	SLA, AGM, EFB, GEL, Li-Ion	Backlit Digital Display	Battery Diagnostics, Memory Saver Port, Polarity Protection & Indicator, Adjustable Charge

Waste Oil Collection

	Tote-Top Mega Funnel				
	The Heavy-Duty HDPE Tote-Top Mega Funnel Features a Large Removable Metal Screen & Center Opening To Drain Fluid Into an IBC Tote Without a Mess. The Tote Top Mega Funnel Fits Both 275 Gallon & 330 Gallon IBC Totes.				
	WOTTF4048	Removable Screen	Fits 48" x 40" IBC. 30 lbs.		
	Double Walled Used Oil Collection Tanks				
	Collection Tanks are Made From 100% Recyclable, Maintenance Free Polyethylene. The Vented, Weather Resistant Design Includes a Fluid Level Gauge, 2" Top Draw Quick Connect Drain Coupling, Hinged Lockable Manway for Security and a Debris Strainer Basket.				
 Debris Strainer Basket	Part No.	Capacity	Fork Pocket Channels	Manway	Dimensions
	WO5700102N95704	120 Gallons	No	14" Dia	34" Dia x 51"H
	WO5710102N95704	150 Gallons	No	14" Dia	34" Dia x 62"H
	WO5470102N95704	275 Gallons	Yes	18" Dia	47" Dia x 63"H
	WO5760102N95704	360 Gallons	Yes	18" Dia	53" Dia x 63"H
	WO5780102N95704	500 Gallons	Yes	18" Dia	53" Dia x 81"H
	WO5990102N95704	1,000 Gallons	No	18" Dia	81" Dia x 69"H

Fluid Reclaim Equipment

Designed For Drain, Evacuation & Transfer Of Used Oil & Waste Fluids

	Waste Oil Pump Packages			
	WO647016DPP	Graco 1050 Diaphragm Pump (1", 50gpm), Funnel & Hose Kit. NOT Included: Roth Double Wall Tank, Level Gauge and Mounting Bracket.		
	Graco Oil King and Coolant King			
	Polyethylene Tank Features Large Funnel, Tool Holders, Sight Gauge, Used-Filter Tray, Removable Filter Screen, 3" Buttress Inlet Port, 3/4"NPT Outlet			
	WFG238866	Oil King (Black)	25 Gallons	Adjustable Height 45" to 69". 24"W x 24"L.
WFG248632	Coolant King (Green)	25 Gallons		
	Self Evacuation Portable Oil Drain			
	Includes auto-check technology for easy and automatic drain evacuation. Steel tanks have a 4-caster design, 16"OD funnel and pressure relief safety valve.			
	WOJD18DC	6' Discharge Hose.	18 Gallons	Adjustable Height 36.5" to 59". 42 Lbs.
	WOJD25DC	Heavy Duty Model with a Sight Glass, Molded Poly Tool Tray, & 6' Discharge Hose.	25 Gallons	Adjustable Height 50" to 70". 85 Lbs.
	Truck and Tractor Low Profile Oil Drain			
	Constructed of rugged steel and has an expanded metal shield for reduced splash, 10" ground clearance, 6" industrial casters and 35" long reach folding T-Handle.			
	WOLP17	Includes a Gate Valve for Gravity Feed. 150 Lbs.	17 Gallons	48"L x 25"W x 10"H
	WOLP25	Includes 110v Electric Pump (Self-Contained) & 10' Evacuation Hose. 160 Lbs.	25 Gallons	48"L x 25"W x 10"H
	Oil and Coolant Drain Pans			
	High-density polyethylene material features a 1"spout, an anti-splash lip and baffle.			
	OTL17972	Oil Drain Pan (Black)	4.5 Gallons	



Samson Used Oil Drains

	FHS3733	18 Gallon Waste Oil Drain with Remote Pump Discharge and Telescopic Bowl.		FHS3720	27 Gallon Waste Oil Suction & Gravity Drain with a 10 Qt. Transparent Chamber and Height Adjustable Collection Bowl, Level Gauge and Anti-Splash Screen.
	FHS3734	18 Gallon Waste Oil Drain with Pressure Discharge and Telescopic Bowl.		FHS3721	27 Gallon Waste Oil Suction with a 10 Qt. Transparent Chamber and Height Adjustable Collection Bowl, Level Gauge and Anti-Splash Screen.
	FHS3731K	18 Gallon Waste Oil Suction Drain with 10 Qt. Transparent Chamber and 8 Piece Wand Kit.		FHS3723	27 Gallon Waste Oil Drain with Remote Pump Discharge and Height Adjustable Collection Bowl, Level Gauge and Anti-Splash Screen.
				FHS3724	27 Gallon Waste Oil Drain with Pressure Discharge Features a Telescopic Bowl.

Dispense Containers and Funnel Kits

Oil Safe Dispense Container		Funnels and Funnel Kits						
	OSD10	Industrial Grade Drum, 10 Quart/Liter		OTL24970	Spill-Free Coolant Funnel Kit Includes cap for VW, Audi and Porsche overflow tanks with threaded caps. Colored adapters for quick ID. 7"W x 9"D x 7"H			
	OSD5	Industrial Grade Drum, 5 Quart/Liter						
	OSL25	Oil Safe Lid, 1" (25mm) Nozzle		OTL19342	Multi-Application Funnel 1.6 qt. translucent funnel with (7) color-coded adapters & 45° elbow. 6.5"W x 5.5"D x 7.25"H			
	OSL12	Oil Safe Lid, 0.5" (12mm) Nozzle						
	OSH25	Oil Safe Hose, 1" (25mm) Nozzle, 9"L						
	OSH12	Oil Safe Hose, 0.5" (12mm) Nozzle, 12"L						
Economy Grade Containers					OTL19802	Threaded Super Funnel Threaded large section. Small funnel fits small areas (transmission filler holes). 4.75"OD x 15.5"H		
	OTL19702	Translucent Polyethylene Container with Flexible 8" Spout, Spout Lid & Cap, Markings in Quarts & Liters.					OTL19832	Translucent Funnel Polypropylene Funnel, 1.6 qt. 4" opening, with lid and spout cap. 6.5"W x 15.25"H
	OTL19732	8 Quart Container, 15.5"H						
	OTL19602	Low Profile Translucent Polyethylene Dispenser with Shut-Off Valve & Lid. Markings in Quarts & Liters.						
	OTL19602	Low Profile 8 Quart 15.75"L x 7"W x 9.5"H						

Toucan Absorbent Recycling System

Save Time, Reduce Expenses & Efficiently Clean Up Spills. The Toucan Cart Stores, Dispenses, & Recycles Fibercan+ Absorbent From Waste.

Designed for auto shops, industrial workshops, and service operations that demand fast and cost-effective spill management. This rugged, mobile station stores, distributes, and recycles Fibercan+ Absorbent locking in oils, coolants, and fluids the moment they hit the surface, leaving no greasy residue behind for a cleaner workspace.

LIQ-LOCK® Absorbent Technology
Encapsulates Fluid on Contact



Toucan Absorbent Recycling System Features

- All-In-One Station Stores, Distributes, & Recycles Fibercan+ Absorbent Efficiently.
- Recycling Sifting System Instantly Separates Soiled From Reusable Absorbent.
- Safe, Reliable, & Eco-Conscious Spill Management.
- Fibercan+ Absorbs Fluids Without Leaving Greasy Residue.



Toucan Absorbent Recycling Bundle	
Includes Toucan Cart and (1) Bag of FIBERCAN+ Absorbent Powder.	
Toucan Bundle	Part No. SRTOU0015B
Overall Dims:	44.1"W x 31.3"L x 25.6"H
Storage Tank Vol.	11.9 Gallons
Weight	52 Lbs.
Waste Tank Vol.	4.8 Gallons
Sifting Grid Dims:	14"W x 9"L / .15" Perforations
FIBERCAN+ Absorbent Powder Refill Bag	Part No. SRFAC001
Lignocellulose absorbent powder traps liquids & eliminates oil and grease residue. Use with Toucan Absorbent Recycling System. 7.9 Gal Refill Bag.	

Ambient Ocean Lagoon Biological Parts Washer

Eco-Friendly & Solvent-Free Portable System Cleans at Room Temperature, Perfect for Mobile Workshops, Powersports, & Off-Road Maintenance

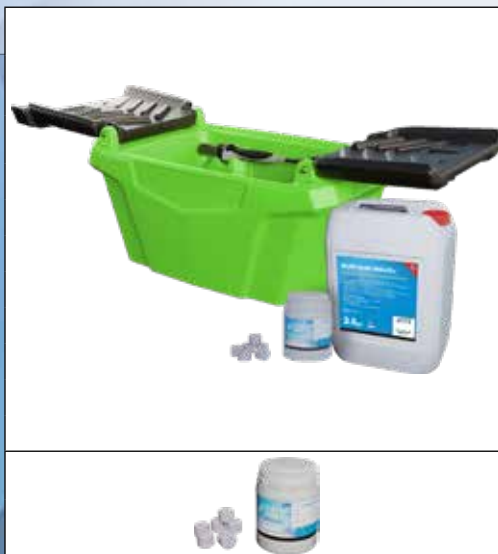

Ocean Lagoon Biological Parts Washer Bundle	
Includes Ocean Lagoon Parts Washer, ClearTabs SRCT, Box of 6 and (1) BlueLiquid SRBLPE+ Aqueous Solution, 2.5 Gal Container.	
Ocean Lagoon Bundle	Part No. SR0014019B
Operating Capacity	2.6 Gallons
Operating Temperature	Room Temperature
Pump Flow Rate	158 GPH
Filtration	Stainless steel filter cup 0.027in
Working Dimensions	19.3"W x 12.6"L x 7.1"H
Overall Dimensions	28"W x 17.3"L x 14.2"H
Unit Weight	20 Lbs
Optional Vehicle Ready Power Source	Vehicle 6V Lighter Socket
ClearTabs (Box of 6)	Part No. SRCT6
Solvent-free cleaning tablet solution removes oils, grease, and contaminants at room temperature. Use with Ocean Lagoon.	

Ocean Lagoon Biological Parts Washer Features

- Portable 2.6 gallon system with dual handles & magnetic lid closure make transport effortless.
- Room-temperature cleaning power combines BlueLiquid & ClearTab microbes to break down contaminants safely.
- Multi-function washer lid holds parts, collects drips, and stores brushes for organized cleaning.

Heated Biological Part Washers

Solvent-Free and Heat Regulated Biological Parts Washers Deliver Heavy-Duty, Eco-Friendly Cleaning



Gravity X2 Mobile Biological Parts Washer	
This 10-gallon mobile system brings biological cleaning directly to the job. It features controlled 100°F heat for safe cleaning of sensitive parts, an ergonomic table and casters for easy transport, with 15-minute cycles for rapid cleaning wherever it's needed.	
Gravity X2 Parts Washer (Bundle Includes Parts Washer, (1) BlueTablet Box of 4 & (2) BlueLiquid SRBLPE+ Aqueous Solution 5 Gal Pails).	Gravity X2 Bundle Part No.: SRGRV0717B
	Gravity X2 Only: Part No. SRGRVE108
Operating Capacity	10 Gallons
Operating Temperature	Low Pressure Heat Regulated To 100°F
Pump Flow Rate	Adj. 0 To 1.58 GPM & Low Flow Tap
Filtration	Bag filter polypropylene 0.002in
Soaking Dimensions	8"W x 8.3"L x 3.1"H / 1 Gallon
Overall Dimensions	32.3"W x 20.9"L x 41.4"H
Unit Weight	50.7 Lbs





Ocean Sunset Biological Parts Washer	
The 26-gallon heated biological system maintains 100°F, with Boost Mode up to 109°F for heavy soils. Features an integrated cleaning table to keeps parts organized, & a 300 GPH circulation pump for consistent flow across all surfaces. A hermetic sealed lid preserves heat and performance. Integrated casters make positioning around the shop effortless.	
Ocean Sunset Parts Washer (Bundle Includes Parts Washer, (1) BlueTablet Box of 4 & (5) BlueLiquid SRBLPE+ Aqueous Solution 5 Gal Pails).	Ocean Sunset Bundle Part No.: SRSUN0623B
	Ocean Sunset Only: Part No. SRSUN6117
Operating Capacity	26 Gallons
Operating Temperature	100°F Standard, 109°F Boost Mode
Pump Flow Rate	300 GPH
Filtration	0.03in Basket Filter + 0.004in External Filter
Working Dimensions	31"W x 16"L x 7"H / 8 Gallons Soaking
Overall Dimensions	36"W x 26"L x 44"H
Unit Weight	88 Lbs.



Blue Tablets (Box of 4)	Part No. SRBT4
Enhances BlueLiquid aqueous solution in biological washers. Extends solution life, reduces sludge, neutralizes odors, & boosts microbial activity to maintain a clean, effective bath. Use with Gravity X2 and Ocean Sunset.	

Solvent-Free Cleaning Solutions

Clean & Remove Grease, Oil, Carbon, & Deposits.

Aqueous Solutions	
Use with Ocean Lagoon, Ocean Sunset, and Gravity X2 Parts Washers.	
	SRBLC275 BlueLiquid SRBLC+ Aqueous Solution, 275 Gal for 5:1 Dilution
	SRBLC55 BlueLiquid SRBLC+ Aqueous Solution, 55 Gal for 5:1 Dilution
	SRBLC5G BlueLiquid SRBLC+ Aqueous Solution, 5 Gal for 5:1 Dilution
	SRBLPE5 BlueLiquid SRBLPE+ Aqueous Solution, 5 Gal Pail - Ready To Use

Ultra-Spill Pallets - Plus, Standard, Economy

Spill Containment Pallets Combine Safety, Budget & Storage Requirements.
Meets SPCC, EPA Container Storage Regulation 40 CFR 264.175.

	Part#	Description	Dimensions	Load Capacity	Capacity	WT.
	CV9606	Ultra-Spill Pallet Plus Nearly 50% Lower Than Standard Models, and Features a Forkliftable All-Polyethylene Construction with Removable Non-Slip Grate Surfaces.	P1 Pallet Plus (1 Drum) Without Drain 2-Way Forklift Access	40" x 40" x 12"	800 Lbs.	62 Gal. 51 Lbs.
	CV9607		P1 Pallet Plus (1 Drum) With Drain 2-Way Forklift Access	40" x 40" x 12"	800 Lbs.	62 Gal. 51 Lbs.
	CV9610		P2 Pallet Plus (2 Drum) Without Drain 2-Way Forklift Access	65½" x 40" x 8¾"	4,500 Lbs.	66 Gal. 88 Lbs.
	CV9611		P2 Pallet Plus (2 Drum) With Drain 2-Way Forklift Access	65½" x 40" x 8¾"	4,500 Lbs.	66 Gal. 88 Lbs.
	CV9626		P3 Pallet Plus (3 Drum) Without Drain 2-Way Forklift Access	83" x 34½" x 8¾"	4,500 Lbs.	66 Gal. 90 Lbs.
	CV9627		P3 Pallet Plus (3 Drum) With Drain 2-Way Forklift Access	83" x 34½" x 8¾"	4,500 Lbs.	66 Gal. 90 Lbs.
	CV9630		P4 Pallet Plus (4 Drum) Without Drain 4-Way Forklift Access	62" x 62" x 8¾"	9,000 Lbs.	75 Gal. 140 Lbs.
	CV9631		P4 Pallet Plus (4 Drum) With Drain 4-Way Forklift Access	62" x 62" x 8¾"	9,000 Lbs.	75 Gal. 140 Lbs.
	CV0678	P1 Ramp, Non-slip, Polyethylene & Steel	68½" x 28½" x 12"	700 Lbs.		74 Lbs.
	CV0676	P2, P3 & P4 Ramp, Non-slip, Polyethylene & Steel	55½" x 28½" x 8¾"	700 Lbs.		43 Lbs.
	CV9614	P2 Pullover Cover				
	CV9634	P4 Pullover Cover				
	CV1010	Ultra-Spill Pallet Standard Built For Heavy Loads & Convenient Drum Handling.	P2 Pallet (2 Drum) Without Drain 2-Way Forklift Access	53" x 29" x 16½"	3,000 Lbs.	66 Gal. 63 Lbs.
	CV1011		P2 Pallet (2 Drum) With Drain 2-Way Forklift Access	53" x 29" x 16½"	3,000 Lbs.	66 Gal. 63 Lbs.
	CV1000		P4 Pallet (4 Drum) Without Drain 4-Way Forklift Access	53" x 53" x 11¾"	6,000 Lbs.	66 Gal. 90 Lbs.
	CV1001		P4 Pallet (4 Drum) With Drain 4-Way Forklift Access	53" x 53" x 11¾"	6,000 Lbs.	66 Gal. 90 Lbs.
	CV0678	Ramp, Non-Slip, Polyethylene & Steel	68½" x 28½" x 12"	700 Lbs.		74 Lbs.
	CV1006	P4 Pullover Cover				
	CV1016	P2 Pullover Cover				
	CV2504	Ultra-Spill Pallet Economy The First Recycled Spill Pallet On The Market. Black Color Helps Hide Dirt & Grime.	P2 Economy (2 Drum) Without Drain 2-Way Forklift Access	53" x 29" x 16½"	1,500 Lbs.	66 Gal. 63 Lbs.
	CV2505		P2 Economy (2 Drum) With Drain 2-Way Forklift Access	53" x 29" x 16½"	1,500 Lbs.	66 Gal. 63 Lbs.
	CV1112		P4 Economy (4 Drum) Without Drain 4-Way Forklift Access	53" x 53" x 11¾"	3,000 Lbs.	66 Gal. 85 Lbs.
	CV1113		P4 Economy (4 Drum) With Drain 4-Way Forklift Access	53" x 53" x 11¾"	3,000 Lbs.	66 Gal. 85 Lbs.
	CV0678	Ramp, Non-slip, Polyethylene & Steel	68½" x 28½" x 12"	700 Lbs.		74 Lbs.
	CV1006	P4 Pullover Cover				
	CV1016	P2 Pullover Cover				

Ultra-Spill Pallets - Nestable, King, Flexible, Steel

Spill Containment Pallets Combine Safety, Budget & Storage Requirements.
Meets SPCC, EPA Container Storage Regulation 40 CFR 264.175.

	Part#	Description	Dimensions	Load Capacity	Capacity	WT.	
	CV1230	Ultra-Spill Pallet Nestable Low-Profile, Nestable Pallet.	Nestable Pallet (4 Drum) Without Drain 2-Way Forklift Access	51" x 51" x 10"	6,000 Lbs.	66 Gal.	80 Lbs.
	CV1231		Nestable Pallet (4 Drum) With Drain 2-Way Forklift Access	51" x 51" x 10"	6,000 Lbs.	66 Gal.	80 Lbs.
	CV0676	Ramp, Non-slip , Polyethylene & Steel	55½" x 28½" x 8¾"	700 Lbs.		43 Lbs.	
	CV1006	P4 Pullover Cover					
	CV0801	Ultra-Spill King Combines a Forkliftable Top Grate With a Forkliftable Bottom Sump. Drums Can Be Moved While Keeping The Sump In Place. Drums can also be Double Stacked.	Spill King (4 Drum) Without Drain 2-Way Forklift Access	51" x 51" x 17½"	6,500 Lbs.	85 Gal.	110 Lbs.
	CV0802		Spill King (4 Drum) With Drain 2-Way Forklift Access	51" x 51" x 17½"	6,500 Lbs.	85 Gal.	110 Lbs.
	CV300 0801	Drum Pallet Only	48¾" x 48¾" x 5½"	15,000 Lbs.		57 Lbs.	
	CV1340	Ultra-Spill Pallet Flexible Heavy-Duty 18 Oz. PVC Yellow Sump, Rolls Down for Convenient Storage. The Grating Rests On A Ribbed Polyethylene Deck With Interconnecting Load-Bearing Walls, Providing Strong Support.	P2 Pallet Flexible, Without Drain	48" x 24" x 14"	1,200 Lbs.	66 Gal.	30 Lbs.
	CV1345		P2 Pallet Flexible, With Drain	48" x 24" x 14"	1,200 Lbs.	66 Gal.	30 Lbs.
	CV1341		P4 Pallet Flexible, Without Drain	48" x 48" x 7"	2,400 Lbs.	66 Gal.	49 Lbs.
	CV1346		P4 Pallet Flexible, With Drain	48" x 48" x 7"	2,400 Lbs.	66 Gal.	49 Lbs.
	CV1180	Ultra-Spill Pallet Steel Heavy-Duty, 14-Gauge Galvanized Steel Construction Will Not Melt Or Deform From Extreme Heat Or Fire. Removable Grate.	S2 Pallet Steel (2 Drum) 2-Way Forklift Access	32" x 48" x 18"	2,575 Lbs.	68 Gal.	115 Lbs.
	CV1182		S4 Pallet Steel (4 Drum) 4-Way Forklift Access	47.25" x 49.25" x 13"	3,875 Lbs.	68 Gal.	170 Lbs.

Ultra-Spill Drum Decks - Standard, Plus & Inline

Low Profile Modular Decks Built For Efficient Drum Handling.

Meets SPCC, EPA Container Storage Regulation 40 CFR 264.175.

	Part#	Description		Dimensions	Load Capacity	Capacity	WT.	
	CV1321	Ultra-Spill Deck Standard	Bulkhead Fittings Connect The Modules Together While Permitting Spilled Fluid To Flow From One Module To The Next.	P1 Deck	25.9" x 25.9" x 5.8"	1,500 Lbs.	11 Gal.	21 Lbs.
	CV1086			P2 Deck	52" x 25.9" x 5.8"	3,000 Lbs.	22 Gal.	40 Lbs.
	CV1072			P4 Deck	52" x 52" x 5.8"	6,000 Lbs.	44 Gal.	70 Lbs.
	CVLR 1089	Loading Ramp		32" x 24" x 5.8"	600 Lbs.		17 Lbs.	
	CV1073	Bulkhead Fitting		2.5" x 2.5" x 2.5"			1 Lb.	
	CV1131	26" T-Strip		26" x 1.5" x 1.5"			1 Lb.	
	CV2222	Ultra-Spill Deck Plus	Has a High Weight Rating of 10,000 Lbs./ Sq Ft & Connects Via Bulkhead Fittings to Combine 2 & 4 Drum Modules in Unlimited Configurations.	P2 Deck Plus	54.5" x 27.3" x 4.3"	10,000 Lbs./ Sq Ft	17.5 Gal.	56 Lbs.
	CV2223			P4 Deck Plus	54.5" x 54.5" x 4.3"	10,000 Lbs./ Sq Ft	35 Gal.	104 Lbs.
	CV2353	Steel Ramp		37" x 26.5" x 4.3"	1,000 Lbs.		78 Lbs.	
	CV2360	The Narrow Depth Spill Decks Allows Drums to be Stored in a Single Row Along Facility Walls, While Connected Modules Can Lock Together To Let Spills Flow Between Them. Additional Modules Can Be Easily Added To Expand The Configuration.	Inline Deck (3 Drum)	77.9" x 25.9" x 5.8"	4,500 Lbs.	99 Gal.	67 Lbs.	
	CV2361		Inline Deck (4 Drum)	104" x 25.9" x 5.8"	6,000 Lbs.	110 Gal.	84 Lbs.	
	CV2333		Inline Deck (5 Drum)	129.9" x 25.9" x 5.8"	7,500 Lbs.	121 Gal.	107 Lbs.	
	CV2334		Inline Deck (6 Drum)	156" x 25.9" x 5.8"	9,000 Lbs.	66 Gal.	132 Lbs.	
	CVLR 1089		Loading Ramp	32" x 24" x 5.8"	600 Lbs.		17 Lbs.	
	CV2317		Bladder Attachment	25.9" x 4.6" x 4.6"		66 Gal.	4 Lbs.	
	CV2345		Bladder Pump	12" x 7" x 5.5"			3 Lbs.	
	CV6340		Bladder Replacement	66" x 65.5" x 4.5"		66 Gal.	2 Lbs.	
	CV1175	Ultra-Spill Deck P6 & P8	Feature A One-Piece Molded Sump With Elevated 2' X 4' Grates. No Bulkhead Or Modules Required.	P6 Deck (6 Drum)	74.3" x 50" x 5.25"	9,000 Lbs.	66 Gal.	86 Lbs.
	CV1075			P8 Deck (8 Drum)	98.5" x 50" x 5.25"	12,000 Lbs.	75 Gal.	110 Lbs.
	CVLR 1089	Loading Ramp		32" x 24" x 5.8"	600 Lbs.		17 Lbs.	

Ultra-Spill Drum Decks - Flexible & Bladder Systems

Meets SPCC, EPA Container Storage Regulation 40 CFR 264.175.

	Part#	Description		Dimensions	Load Capacity	Capacity	WT.
	CV1320	Ultra-Spill Deck Bladder System Small Leaks Collect In The Sump While The Bladder Deploys for Major Leaks to Meet Compliance.	P1 Deck Bladder Sys.	30.5" x 25.9" x 5.8"	1,500 Lbs.	W/Bladder: 77 Gal. Sump Only: 11 Gal.	27 Lbs.
	CV2329		P2 Deck Bladder Sys.	52" x 30.5" x 5.8"	3,000 Lbs.	W/Bladder: 88 Gal. Sump Only: 22 Gal.	44 Lbs.
	CV2330		P4 Deck Bladder Sys.	56.6" x 52" x 5.8"	6,000 Lbs.	W/Bladder: 110 Gal. Sump Only: 44 Gal.	66 Lbs.
	CVLR 1089	Loading Ramp		32" x 24" x 5.8"	600 Lbs.		17 Lbs.
	CV2317	Bladder Attachment		25.9" x 4.6" x 4.6"		66 Gal.	4 Lbs.
	CV2345	Bladder Pump		12" x 7" x 5.5"			3 Lbs.
	CV6340	Bladder Replacement		66" x 65.5" x 4.5"		66 Gal.	2 Lbs.
	CV1350	Ultra-Spill Deck Flexible Heavy-Duty 18 oz. PVC Yellow Sump Folds for Storage. Connect Decks With Bulkhead Fittings. Note: Connect Multiple Decks With Bulkhead Fittings to Meet SPCC, EPA Container Storage Regulation 40 CFR 264.175.	P1 Deck Flexible	24" x 24" x 2.5"	1,500 Lbs.	5.5 Gal.	12 Lbs.
	CV1351		P2 Deck Flexible	48" x 24" x 2.5"	3,000 Lbs.	11 Gal.	22 Lbs.
	CV1352		P4 Deck Flexible	48" x 48" x 2.5"	6,000 Lbs.	22 Gal.	44 Lbs.
	CV1358	Flex Bridge		22" x 2" x 1.5"		2 Gal.	0.9 Lbs.
	CV1357	Bulkhead Fitting					0.1 Lbs.
	CV2345	Bladder Pump		12" x 7" x 5.5"			3 Lbs.
	CV1360	Ultra-Spill Deck Bladder System Flexible Heavy-Duty 18 oz. PVC Outer Yellow Sump Folds for Storage. Connect Decks With Bulkhead Fittings. Incidental Leaks are Contained While a Catastrophic Spill Triggers The 66 Gallon Capacity Bladder.	P1 Deck Flexible Bladder Sys.	27" x 24" x 5"	1,500 Lbs.	77 Gal.	15 Lbs.
	CV1361		P2 Deck Flexible Bladder Sys.	48" x 27" x 5"	3,000 Lbs.	88 Gal.	26 Lbs.
	CV1362		P4 Deck Flexible Bladder Sys.	51" x 48" x 5"	6,000 Lbs.	110 Gal.	50 Lbs.
	CV1359	Bladder Replacement		66" x 58"		66 Gal.	2 Lbs.
	CV2345	Bladder Pump		12" x 7" x 5.5"			3 Lbs.
	CV2420	Ultra-Safety Cabinet Bladder System Includes Yellow Polyethylene Sump, Black Steel Frame & Bladder Attachment. Supports an Existing Safety Cabinet (NOT Included).	Cabinet Bladder Sys. (1 Drum)	37.8" x 37.8" x 6.3"	1,500 Lbs.	93 Gal.	57 Lbs.
	CV2421		Cabinet Bladder Sys. (2 Drum)	63" x 38.5" x 6.3"	3,000 Lbs.	111 Gal.	85 Lbs.

Ultra-Hard Tops for Drums

**Outdoor Enclosed Hard-Top Spill Containment Systems for Multiple Drums.
Meets SPCC, EPA Container Storage Regulation 40 CFR 264.175.**

	Part#	Description	Dimensions	Load Capacity	Capacity	WT
	CV1082	Ultra-Hard Top Secure 66 Gallon	P2 Hard Top (2 Drum) Without Drain 57" x 30.5" x 63.5"	3,000 Lbs.	66 Gal.	173 Lbs.
	CV1083	Outdoor Secondary Containment For 2	P2 Hard Top (2 Drum) With Drain 57" x 30.5" x 63.5"	3,000 Lbs.	66 Gal.	173 Lbs.
	CV1080	or 4 55-Gallon Drums Constructed From UV	P4 Hard Top (4 Drum) Without Drain 57" x 54" x 64.5"	6,000 Lbs.	66 Gal.	226 Lbs.
	CV1081	Inhibited Polyethylene with "Gull Wing" Design and Removable Grates.	P4 Hard Top (4 Drum) With Drain 57" x 54" x 64.5"	6,000 Lbs.	66 Gal.	226 Lbs.
	CV0678		Ramp for P4 Only 68.5" x 28.5" x 12"	700 Lbs.		74 Lbs.
	CV9640	Ultra-Hard Top Plus 2-Piece, Lockable with Roll-Top Cover to Access Pumps/Funnels. Constructed From UV Inhibited Polyethylene.	P1 Hard Top Plus (1 Drum) Without Drain 36" x 36" x 66"	800 Lbs.	70 Gal.	62 Lbs.
	CV9641		P1 Hard Top Plus (1 Drum) With Drain 36" x 36" x 66"	800 Lbs.	70 Gal.	62 Lbs.
	CV0417	Steel Dolly for Ultra-Hard Top P1 Plus Only	26.5" x 26.5" x 5"	700 Lbs.		35 Lbs.
	CV9612	Ultra-Hard Top Plus Low-Profile	P2 Hard Top Plus (2 Drum) Without Drain 67.3" x 41.3" x 74"	4,500 Lbs.	66 Gal.	260 Lbs.
	CV9613	Forkliftable, Lockable Containment With Roll-Top and Swing-Out Doors, Full Access For Pumps, Funnels, & Equipment. Constructed From UV Inhibited Polyethylene.	P2 Hard Top Plus (2 Drum) With Drain 67.3" x 41.3" x 74"	4,500 Lbs.	66 Gal.	260 Lbs.
	CV9636		P4 Hard Top Plus (4 Drum) Without Drain 64.5" x 62" x 79"	9,000 Lbs.	75 Gal.	440 Lbs.
	CV9637		P4 Hard Top Plus (4 Drum) With Drain 64.5" x 62" x 79"	9,000 Lbs.	75 Gal.	440 Lbs.
	CV0676		Ramp, Polyethylene 55.5" x 28.5" x 8.8"	700 Lbs.	N/A	43 Lbs.
	CV9650	Ultra-Hard Top Plus Multiple 4 Drum Compartments For 8 To 20+ Drums. 2-Way Entry & Separate Lockable Compartments. Roll-Top & Swing-Out Doors, Full Access For Pumps & Equipment.	P8 Hard Top Plus (8 Drum) Without Drain 126" x 62" x 79"	9,000 Lbs.	75 Gal.	815 Lbs.
	CV9651		P8 Hard Top Plus (8 Drum) With Drain 126" x 62" x 79"	9,000 Lbs.	4 Drum Comp.	
	CV9652		P12 Hard Top Plus (12 Drum) W/out Drain 188" x 62" x 79"	9,000 Lbs.	75 Gal.	1,190 Lbs.
	CV9653		P12 Hard Top Plus (12 Drum) With Drain 188" x 62" x 79"	9,000 Lbs.	4 Drum Comp.	
	CV9654		P16 Hard Top Plus (16 Drum) W/out Drain 250" x 62" x 79"	9,000 Lbs.	75 Gal.	1,565 Lbs.
	CV9655		P16 Hard Top Plus (16 Drum) With Drain 250" x 62" x 79"	9,000 Lbs.	4 Drum Comp.	
	CV9656		P20 Hard Top Plus (20 Drum) W/out Drain 312" x 62" x 79"	9,000 Lbs.	75 Gal.	1,940 Lbs.
	CV9657		P20 Hard Top Plus (20 Drum) With Drain 312" x 62" x 79"	9,000 Lbs.	4 Drum Comp.	
	CV9658	4 Drum Extender Kit, Without Drain	64" x 62" x 79"	9,000 Lbs.	75 Gal.	375 Lbs.
	CV9659	4 Drum Extender Kit, With Drain	64" x 62" x 79"	9,000 Lbs.		
	CV0676	Ramp, Polyethylene Stores Inside Hard Top When Not In Use.	55.5" x 28.5" x 8.8"	700 Lbs.		43 Lbs.
	CV1187	Ultra-Hard Top Steel S4 (4 Drum) Store (4) 55 Gallon Drums. 14 Gauge Steel Offers Protection From Fire & Heat. Hydraulic Lid With 52" Door Opening.	61" x 53" x 55"	4,700 Lbs.	115 Gal.	600 Lbs.

Ultra-Drum Containment Solutions

Industrial Strength Drum Containment Built for Safety and Compliance.
Meets SPCC, EPA Container Storage Regulation 40 CFR 264.175.

	Part#	Description	Dimensions	Load Capacity	Capacity	WT	
	CV2386	Ultra-Drum Rack Containment Systems Polyethylene Drum Racks with Spill Containment Pallets for Safe Dispense From Horizontal 55 Gallon Drums (Tilted Slightly Forward to Maximize Flow).	1 Drum Rack Sys. Without Drain	53" x 29" x 49.5"	750 Lbs.	66 Gal.	93 Lbs.
	CV2387		1 Drum Rack Sys. With Drain	53" x 29" x 49.5"	750 Lbs.	66 Gal.	93 Lbs.
	CV2383		2 Drum Rack Sys. Without Drain	53" x 53" x 44.8"	1,500 Lbs.	66 Gal.	137 Lbs.
	CV2384		2 Drum Rack Sys. With Drain	53" x 53" x 44.8"	1,500 Lbs.	66 Gal.	137 Lbs.
	CV2380		4-Drum Rack Sys. Without Drain	53" x 53" x 77.8"	3,000 Lbs.	66 Gal.	189 Lbs.
	CV2381		4-Drum Rack Sys. With Drain	53" x 53" x 77.8"	3,000 Lbs.	66 Gal.	189 Lbs.
	CV9030	Drum Rack (1 Drum) Polyethylene for 1 Horizontal Drum.		32.5" x 24" x 23.5"			31 Lbs.
	CV2389	Drum Rack (2 Drum) Polyethylene for 2 Horizontal Drums.		46.5" x 30" x 31"			50 Lbs.
	CV2390	Dispense Shelf For Buckets & Safety Cans		24" x 17.5" x 17"			15 Lbs.
	CV2391	Locator Pins, Set of 2 Adds Stability					3 Lbs.
	CV2395	Ultra-Rack Sump For Warehouse Racking. Polyethylene. Holds up to 4 Drums. Forklift Access to Standard Pallet (40"x48" or 48"x48").	Rack Sump (4 Drum) Without Drain	51.5" x 51.5" x 12"		66 Gal.	50 Lbs.
	CV2396		Rack Sump (4 Drum) With Drain/Ball Valve Assy	51.5" x 51.5" x 12"		66 Gal.	50 Lbs.
	CV1782	Drain Hose, Green		25 ft.			3 Lbs.
	CV1792	Drain Hose, Clear		25 ft.			2 Lbs.
	CV1041	Ultra-Spill Collector Forkliftable, Mobile Secondary Drum Containment.	Pallet Jack Collector, Without Drain	32.5 dia" x 28.5"		66 Gal.	28 Lbs.
	CV1044		Pallet Jack Collector, With Drain	32.5 dia" x 28.5"		66 Gal.	28 Lbs.
	CV1040		Flat Bottom Collector, Without Drain	34 dia" x 27.25"		66 Gal.	27 Lbs.
	CV1043		Flat Bottom Collector, With Drain	34 dia" x 27.25"		66 Gal.	27 Lbs.
	CV0417	Dolly (For Flat Bottom Unit Only)		26.5" x 26.5" x 5"		N/A	35 Lbs.
	CV1045	Ultra-Drum Tray NOT Sized for SPCC/ EPA Regulations. For Everyday Drips & Overflows. Optional Grate Keeps Drums Elevated Above Any Collected Fluid.	Drum Tray Without Grating	32" x 32" x 8.1"		22.8 Gal.	19 Lbs.
	CV1046		Drum Tray With Grating	32" x 32" x 8.1"		21.1 Gal.	26 Lbs.
	CV0417	Dolly (For Flat Bottom Unit Only)		26.5" x 26.5" x 5"	800 Lbs.	N/A	35 Lbs.

Ultra-IBC Spill Pallets

**Low-Profile IBC Containment with Heavy-Duty Load Support.
Meets SPCC, EPA Container Storage Regulation 40 CFR 264.175.**

	Part#	Description	Dimensions	Load Capacity	Capacity	WT	
	CV1157	Ultra-IBC Spill Pallet Plus Low Profile, Forkliftable. Supports (1) IBC Container.	IBC Spill Pallet Plus Without Drain (1 IBC)	62" x 62" x 26"	8,500 Lbs.	365 Gal.	230 Lbs.
	CV1158		IBC Spill Pallet Plus With Drain (1 IBC)	62" x 62" x 26"	8,500 Lbs.	365 Gal.	230 Lbs.
	CV1160	Bucket Shelf		19.5" x 16" x 14.5"	3 Gal.	10 Lbs.	
	CV1159	Pullover Cover					
	CV1057	Ultra-IBC Spill Pallet Safely Double Stack (2) IBC Containers. Removable Grating & Support.	IBC Spill Pallet Without Drain (2 IBC)	58.75" x 58.75" x 33"	16,000 Lbs.	400 Gal.	444 Lbs.
	CV1058		IBC Spill Pallet With Drain (2 IBC)	58.75" x 58.75" x 33"	16,000 Lbs.	400 Gal.	444 Lbs.
	CV1140	Ultra-Twin IBC Spill Pallet One Continuous Sump Holds 535 Gallons for 2 IBC Tanks.	Twin IBC Pallet (2 IBC) W/out Drain	124.5" x 61.6" x 22"	8,000 Lbs.	535 Gal.	353 Lbs.
	CV1141		Twin IBC Pallet (2 IBC) W/out Drain, 1 Bkt Shlf (R)	124.5" x 61.6" x 22"	8,000 Lbs.	535 Gal.	361 Lbs.
	CV1142		Twin IBC Pallet (2 IBC) W/out Drain, 1 Bkt Shlf (L)	124.5" x 61.6" x 22"	8,000 Lbs.	535 Gal.	361 Lbs.
	CV1143		Twin IBC Pallet (2 IBC) W/out Drain, 2 Bkt Shlvs	124.5" x 61.6" x 22"	8,000 Lbs.	535 Gal.	373 Lbs.
	CV1144		Twin IBC Pallet (2 IBC) With Drain	124.5" x 61.6" x 22"	8,000 Lbs.	535 Gal.	353 Lbs.
	CV1145		Twin IBC Pallet (2 IBC) With Drain, 1 Bkt Shlf (R)	124.5" x 61.6" x 22"	8,000 Lbs.	535 Gal.	361 Lbs.
	CV1146		Twin IBC Pallet (2 IBC) With Drain, 1 Bkt Shlf (L)	124.5" x 61.6" x 22"	8,000 Lbs.	535 Gal.	361 Lbs.
	CV1147		Twin IBC Pallet (2 IBC) With Drain, 2 Bkt Shlvs	124.5" x 61.6" x 22"	8,000 Lbs.	535 Gal.	373 Lbs.
	CV1184	Ultra-IBC Spill Pallet Steel (1 IBC) Features 4-Way Forkliftable Access & Removable Grates. Constructed With 14 Gauge Galvanized Steel. Provides Secondary Containment for Chemicals, Hazardous Materials & Flammable Liquids.		58" x 58" x 35"	5,650 Lbs.	370 Gal.	375 Lbs.

Ultra-Modular IBC Spill Pallets

Modular Indoor/Outdoor IBC Spill Pallets Connect for Efficient Containment. Meets SPCC, EPA Container Storage Regulation 40 CFR 264.175.

	Part#	Description	Dimensions	Load Capacity	Capacity	WT	
	CV1118	Ultra-Modular IBC Spill Pallet (Indoor)	Assembly Kit (REQUIRED)				2 Lbs.
	CV1125	Each IBC Sits on a Low Profile 75 Gallon IBC Spill Pallet.	Modular Pallet (2 IBC) 2 Expansion Tanks & 2 Pallets Included	186" x 62" x 11"	9,000 Lbs.	280 Gal.	310 Lbs.
	CV1126	Expansion Tanks Provide an Add'l 65 Gallons Capacity. Bulkhead Fittings	Modular Pallet (3 IBC) 2 Expansion Tanks & 3 Pallets Included	248" x 62" x 11"	9,000 Lbs.	355 Gal.	435 Lbs.
	CV1127	Connect Spill Pallets & Expansion Tanks, Allowing a Spill to be Channeled Throughout the System.	Modular Pallet (4 IBC) 1 Expansion Tank & 4 Pallets Included	279" x 62" x 11"	9,000 Lbs.	365 Gal.	531 Lbs.
	CV1128		Modular Pallet (5 IBC) 0 Expansion Tanks & 5 Pallets Included	310" x 62" x 11"	9,000 Lbs.	375 Gal.	625 Lbs.
	CV9630	Spill Pallet Only		62" x 62" x 8.75"	9,000 Lbs.	75 Gal.	140 Lbs.
	CV1124	Expansion Tank Only		61" x 31" x 12.5"		65 Gal.	30 Lbs.
	CV1117	1.25" Bulkhead Fittings (Set of 2)		3" x 3" x 3"			2 Lbs.
	CV1118	Ultra-Modular IBC Spill Pallet (Outdoor)	Assembly Kit (REQUIRED)				2 Lbs.
	CV1165	Lockable Containment With Roll-Top & Swing-Out Doors Offer Full Equipment Access.	Mod O/D Pallet (2 IBC) 2 Expansion Tanks & 2 Pallets Included	126" x 93" x 79"	9,000 Lbs.	280 Gal.	881 Lbs.
	CV1166	Each IBC Sits on a 75 Gallon IBC Spill Pallet. Expansion Tanks Provide an	Mod O/D Pallet (3 IBC) 2 Expansion Tanks & 3 Pallets Included	188" x 93" x 79"	9,000 Lbs.	355 Gal.	1,258 Lbs.
	CV1167	Add'l 65 Gallons of Capacity (1 Tank Per Extender Kit).	Mod O/D Pallet (4 IBC) 1 Expansion Tank & 4 Pallets Included	250" x 93" x 79"	9,000 Lbs.	365 Gal.	1,603 Lbs.
	CV1168	Connect Pallets & Expansion Tanks With Bulkhead Fittings.	Mod O/D Pallet (5 IBC) 0 Expansion Tanks & 5 Pallets Included	312" x 62" x 79"	9,000 Lbs.	375 Gal.	1,948 Lbs.
	CV9658	Extender Kit, Outdoor Model (1 Tank per Extender Kit)		64" x 62" x 79"	9,000 Lbs.	75 Gal.	475 Lbs.
	CV1124	Expansion Tank Only		61" x 31" x 12.5"		65 Gal.	30 Lbs.
	CV1117	1.25" Bulkhead Fittings (Set of 2)		3" x 3" x 3"			2 Lbs.

Spill Containment Trays

Reliable Containment Trays for Small Leaks & Spills from Equipment, Batteries, Pails, Small Containers & Light-Duty Applications.

	Part#	Description	Dimensions	Capacity	Weight
	CV9603	Ultra-Transformer Tray Poly Containment With Molded-In Support for Transformers & Power Distribution Gear. Usable Space 34" X 34".	48" x 48" x 5.6"	50 Gal.	25 Lbs.
	CV2351	Ultra-Containment Tray, Polyethylene Tray Elevates Small Containers & Batteries Above Spills.	Containment Tray, Yellow Without Grating	54" x 29.8" x 3.5"	16.5 Gal. 17 Lbs.
	CV2352		Containment Tray, Yellow With Grating	54" x 29.8" x 3.5"	14 Gal. 34 Lbs.
	CV2328		Containment Tray, Black Without Grating	54" x 29.8" x 3.5"	16.5 Gal. 17 Lbs.
	CV2350		Containment Tray, Black With Grating	54" x 29.8" x 3.5"	14 Gal. 34 Lbs.
	CV1031	Ultra-Utility Tray	48" x 12" x 4.75" Inside Dims.	52.3" x 16.3" x 5"	12 Gal. 8 Lbs.
	CV1032	Heavy-Duty Polyethylene	48" x 24" x 4.75" Inside Dims.	52.3" x 28.3" x 5"	24 Gal. 12 Lbs.
	CV1033	Spill Containment Tray is Nestable & Has a Ribbed Bottom. Keeps Cans, Pails & Containers Elevated	48" x 30" x 4.75" Inside Dims.	52.3" x 34.3" x 5"	30 Gal. 13 Lbs.
	CV1034	Above Any Spills or Leaks.	36" x 24" x 4.75" Inside Dims.	40.3" x 28.3" x 5"	18 Gal. 9 Lbs.
	CV1035		36" x 36" x 4.75" Inside Dims.	40" x 40" x 5"	27 Gal. 11 Lbs.
	CV1036		48" x 40" x 3.5" Inside Dims.	52" x 44" x 4"	30 Gal. 19 Lbs.
	CV1335	Ultra-Utility Tray Flexible One-Piece, High-Visibility PVC Unit. Rolls Up For Compact, Portable Storage. Stores Under a Vehicle Seat, Toolbox, Spill Kit, or Loading Dock for Quick Access.	12" x 12" x 4.8"	1.5 Gal.	1 Lb.
	CV1330		18" x 18" x 4.8"	3.5 Gal.	1 Lb.
	CV1331		24" x 24" x 4.8"	6 Gal.	2 Lbs.
	CV1332		30" x 30" x 4.8"	9.5 Gal.	2.5 Lbs.
	CV1333		42" x 42" x 4.8"	18 Gal.	3.5 Lbs.
	CV1334		48" x 48" x 4.8"	24 Gal.	4 Lbs.
	CV2370	Ultra-Rack Containment Tray Slides Under Pallet Racking & Shelving. Captures Small Leaks & Spills From Palletized Contents Above.	1 Containment Tray, Low Profile	23.5" x 44" x 2.75"	8 Gal. 8 Lbs.
	CV2371		2 Containment Tray System, Low profile	48" x 44" x 2.75"	16 Gal. 19 Lbs.
	CV2372		3 Containment Tray System, Low profile	72" x 44" x 2.75"	24 Gal. 31 Lbs.
	CV2373	Ultra-Rack Containment Tray Connector For Larger Applications	4 Lbs.		
	CV40092W	Drip & Spill Containment Tray Contains Spills and Drips From Machinery, Vehicles, or Drums. Maximum Heat Resistance: Polypropylene Begins to Soften at 180°F when Used Under Equipment.	22" x 22" x 1.5"	2 Gal.	1.8 Lbs.
	CV1060	Ultra-Spill Tray, Small Safely Store Bottles, Beakers & Labware. Has a Built-In Pouring Spout. 13.1" X 8.5" Useable Surface.	17" x 12" x 4"	1.8 Gal.	5 Lbs.
	CV1061	Ultra-Spill Tray, Large Safely Store Bottles, Beakers & Labware. Has a Built-In Pouring Spout. 17.1" X 13.5" Useable Surface.	21" x 17" x 4"	2.9 Gal.	9 Lbs.
	CV5300	Ultra-Line Pipe Tray Captures Drips & Overflows From Pipe and Hose Connections With (2) Channel Sizes Accommodates 2½" and 3½" Pipes.	29" x 24" x 9.25"	4 Gal.	8 Lbs.

CUBETAINER

Gravity Feed Assembly Instructions



Shown with optional containment vessel

Tools Needed:

- 1/2" wrench or crescent wrench
- 9/16" wrench or crescent wrench
- Utility knife
- Flat head screwdriver
- Channel lock pliers

2 Stackable Tank Assembly Shown



Step 1
Screw threaded end of each pipe leg into couplers on the under-side of stand base.



Step 2
Attach drip tray frame to front legs of stand. Leave ample space below the drain valve. NOTE: When using the 203 Gallon Containment Vessel, do NOT install the drip tray kit. (The vessel has a built-in drip tray shelf). In this case place the assembled stand inside the vessel & continue to step 4.



Step 3
Place drip tray pans and screens into the drip tray frame spaces. NOTE: Handle drip tray screens with care, outside edges are sharp. We recommend wearing gloves when handling drip tray screens.



Step 4
Attach elbow kit(s) to front lip of the stand base, using 1/2" wrench. Repeat as necessary.



Step 5
Stack all tanks on the stand. Tanks will interlock snugly, resisting any pressure front-to-back, or side-to-side.



Step 6
Install valve directly into bottom tank 1" NPT drain port. Install additional valves into 1" NPT Elbow kit opening on stand.

IMPORTANT: DO NOT OVERTIGHTEN. HAND TIGHTEN ONLY.



Step 7
Install a poly elbow into each upper tank's 1" NPT drain port. Angle each poly elbow to a 5 o'clock position, aiming to its installed corresponding stand elbow kit.



Step 8
Install a poly union into each elbow kit on the stand. Elbow kits are naturally angled at an 11 o'clock position, allowing a natural path for the tubing to follow, preventing potential kinks.



Step 9
Cut to clear length poly tubing. Secure a hose clamp on each end and attach tubing to barbed ends of poly elbows and poly union(s).

NOTE: All threaded fittings must be coated with thread sealant to prevent leakage.

Stackable Tank Gravity Feed Assembly Instructions

Tools Needed:

- Flat-head Screwdriver
- Pipe Wrench
- 9/16" Wrench

Components:

- (2) Tanks
- Steel Stand
- Drip Tray Assembly
- Gravity Feed Kit (GFKIT2)



Step 1

Tip or invert stand on concrete base with elbow mount holes to front. Hand tighten 4 legs into couplings, then torque 1/2 to 1 full turn with pipe wrench. The stand can be levelled by adjusting leg heights.



Step 2

Before setting stand right side up, slide drip tray frame down front legs: tighten set screw to hold in place. Place in prepared location, (containment vessel). Adjust drip tray to desired height; tighten. Insert drip trays in frame.



Step 3

Stack one tank on top of assembled stand with bulkhead and fill port facing outward. Align front of tank with front edge of stand (front edge has pre-drilled holes). Stack & interlock each additional tanks, using top and bottom molded grooves.



Step 4

Bolt elbow(s) to the stand's pre-drilled holes.

NOTE: If assembling a Wall-Stacker System, place the wall straps over the top and front of the tank(s). Bolt to bottom of the wall straps to the tank's stand prior to bolting the elbow into place. The top of the wall straps can later be bolted to the wall once the entire system is assembled and positioned in place.



Step 5 IMPORTANT: DO NOT OVERTIGHTEN. Maximum Torque 60 ft. lbs. Hand tighten only.

Apply thread sealant to:

- A) Dispense valve (FOR BOTTOM TANK). Hand tighten into bottom tank bulkhead.
- B) Dispense valve (FOR STACKED TANKS). Hand tighten into front of elbows on stand.



Step 6

Apply thread sealant to 90° barb. Hand tighten into stacked top tanks bulkhead fitting (not bottom tank). Torque until facing five o'clock position.



Step 7

Cut tubing to length, if needed. Place a clamp on each end. Using a screwdriver, secure tubing onto upper tank's 90° barb and the other end onto stud barb.

Remote Fill Kit (RFKIT) Assembly

Tools Needed: Flat-head Screwdriver, 9/16" Wrench

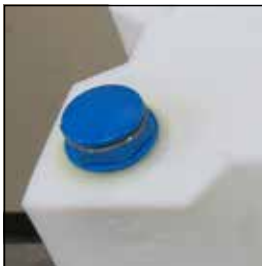

Steps 1-5 Before stacking the upper most poly tank on the system:

Steps 6-7 Complete the Remote Fill Assembly

Step 1

Remove the 2" metal cap from the top of the tank and in its place thread in the included 'blue' Vacuum Breaker.

Step 2

Remove the 2" plastic cap from the top tank's angled fill port and in its place thread the 2" 90° 'black' elbow. Orientate the elbow to face towards the side of the tank.

Step 3

Apply sealant to the 1-1/2" 90° 'black' barbed elbow and thread it into the 2" elbow threaded in the previous step. Orientate the elbow so the barbed end points to the bottom of the tank.

Step 4

Slide one end of the hose over the barbed end of the elbow; secure with hose clamp.

Step 5

Stack the tank at the top of the system and complete the Gravity Feed Assembly Instructions. (Left).

Step 6

Attach the main RFKIT preassembled component (ball valve, hose barb, elbow, and quick connect) to the leg of the stand using the included u-bolts, washers, and nuts.

Step 7

Slide the end of the hose over the barbed end of RFKIT preassembled component and secure with a hose clamp.

Fluidall, LLC Exclusive Manufacturer's Limited Lifetime Tank Warranty

TOTE-A-LUBE / *Wall-Stackers* / **CUBETAINER** / *Slimtainer*

As a result of our superior quality control standards, Fluidall offers a Manufacturer's Limited Lifetime Warranty on our Tote-A-Lube, Wall-Stackers, Cubetainer and Slimtainer rotationally molded storage tanks.

- Limited Warranty.** Fluidall, LLC ("Fluidall") warrants to the original customer that our rotationally molded storage tanks (the "Tanks") will be free from defects in workmanship and materials, under normal use and service, for the serviceable lifetime of the tank starting on the date of shipment from our factory. Fluidall's SOLE OBLIGATION and customer's SOLE REMEDY in the event of a defect covered by this warranty will be, at Fluidall's option, to (a) replace or repair the defective Tank, or (b) refund to customer the purchase price paid by customer for such defective Tank.
- Suspension of Warranty.** Should the customer not pay for a Tank in full as due, Fluidall's warranty shall be deemed suspended until such time as Fluidall receives payment in full for such Tank.
- Obvious Defects.** The carrier and Fluidall must be notified in writing of any and all damage that is discoverable upon a visual inspection of the Tank when it is received and any missing parts or accessories within seventy two (72) hours of receipt of Tank. Any and all such omissions or damage must be noted on the Bill of Lading.
- Installation.** Customer's installation and use of the Tank must comply with all applicable federal, state, and local regulations, and must be in accordance with applicable instructions and limitations contained in Fluidall's Usage and Handling guidelines for the Tank and Fluidall's chemical specific recommendations. Normal maintenance and repair shall be performed by the customer. By accepting delivery of the Tank, the customer accepts full responsibility for providing secondary containment appropriate and adequate for the stored material.
- Warranty Exclusions.** THIS WARRANTY SHALL NOT APPLY TO any Tank that after leaving our factory.
 - Has been repaired or altered in any manner not authorized in writing by Fluidall.
 - Has been damaged in transit or has been subject to abuse, misuse, fire, accident, improper or careless handling or neglect.
 - Has not been used in accordance with Fluidall's chemical resistance recommendations.
 - Has not been serviced and maintained as in accordance with the written instructions provided by Fluidall.
 - Has been exposed to pressures greater than atmospheric pressure.
 - Has been exposed to internal or external temperatures greater than 120° F.
 - Has been connected, installed, adjusted or used other than in accordance with the written instructions provided by Fluidall.
- Warranty Disclaimers.** THIS LIFETIME LIMITED WARRANTY IS IN LIEU OF ALL OTHER WARRANTIES AND GUARANTEES, WHETHER EXPRESSED OR IMPLIED, INCLUDING STATUTORY WARRANTIES, SUCH AS WARRANTIES OF MERCHANTABILITY, FITNESS FOR A PARTICULAR PURPOSE AND/OR NON-INFRINGEMENT AND INCLUDING ANY WARRANTIES ARISING FROM COURSE OF DEALING, USAGE OF TRADE OR OTHERWISE.
- Limited Remedies.** Fluidall's sole liability and the original customers' sole remedy for breach of warranty shall be limited to the remedies provided in Paragraph 1 above. UNDER NO CIRCUMSTANCES SHALL FLUIDALL BE LIABLE TO CUSTOMER OR ANY PERSON CLAIMING THROUGH CUSTOMER FOR SPECIAL, INDIRECT, INCIDENTAL, PUNITIVE OR CONSEQUENTIAL DAMAGES OF ANY DESCRIPTION WHETHER ARISING OUT OF WARRANTY (INCLUDING, WITHOUT LIMITATION, LIMITED WARRANTIES) OR ANY OTHER CONTRACT, NEGLIGENCE OR OTHER TORT OR OTHERWISE. Fluidall also disclaims all liability, whether in contract, tort, warranty or otherwise, to any party other than the original customer.
- Entire Warranty.** This warranty constitutes the full understanding between Fluidall and the original customer regarding the Tanks, and no terms, conditions, understandings, or agreements purporting to modify or vary the terms of this Warranty shall be effective unless made in writing and signed by an authorized representative of Fluidall.
- Limitation of Liability.** In no event shall Fluidall's liability on any claim for damages arising from or connected with the sale, manufacture, delivery or use of the Tanks exceed the purchase price of the Tank. All legal actions for breach of this lifetime limited warranty must be commenced on or before the expiration of one year from the date of such breach. Otherwise, such action shall be considered barred by a period of limitations established by agreement.
- Warranty Procedure.** In order for the Lifetime Limited Warranty to apply, Fluidall must be notified in writing of any alleged defect or fault discovered by the customer within seven (7) days of its occurrence and Fluidall must be given the opportunity to inspect the alleged defective Tank within thirty (30) days of such notification. Fluidall may require the return of the alleged defective Tank to establish the claim. Upon Fluidall's written authority, customer shall return the alleged defective Tank (or portion of the alleged defective product as instructed by Fluidall) to Fluidall for inspection, freight and insurance prepaid by customer. ANY UNAUTHORIZED SHIPMENT OR SHIPMENT CONTRARY TO FLUIDALL'S INSTRUCTIONS WILL VOID THIS LIFETIME LIMITED WARRANTY. Final disposition of any warranty claim will be solely determined by Fluidall. Any attempted repair of a Tank by customer without Fluidall's express, prior written consent WILL VOID THIS LIFETIME LIMITED WARRANTY.

If you have questions about this lifetime limited warranty or have a defective Tank to report, and to receive a shipment authorization number, call or write customer service:

Fluidall LLC
860 Johnson Drive
Delano MN 55328
Tel: 800-849-0591
Fax: 763-972-7401
Email: sales@fluidall.com